



# CE TEST REPORT

FOR

**DC/DC Converter**

Model: PU Series

**Issued to**

**Danube Enterprise Co., Ltd**

A2,NO.255,Fengren Rd., Renwu Shiang Kaohsiung County 814,  
Taiwan (R.O.C.)

**Issue by**

**Global Certification Corp.**

EMI Test Site	Sansia Lab	NO.34-3,Zihhe Rd.,Sansia Township,Taipei County 237, Taiwan ,R.O.C.
EMS Test Site	His Chih office and Lab	No.112-3, Shiang Charng Rd.,Sec. 2, His Chih City,Taipei 221,Taiwan R.O.C.



*Note: This test refers exclusively to the test presented test model and sample. This report shall not be reproduced except in full, without the written approval of Global Certification Corporation. This document may be altered or revised by Global Certification Corporation. Personnel only, and shall be noted in the revision section of the document.*



---

1. GENERAL INFORMATION	3
2. INSTRUMENT AND CALIBRATION	7
3. CONDUCTED EMISSION MEASUREMENT	11
4. RADIATED EMISSION MEASUREMENT	13
5. POWER HARMONIC AND VOLTAGE FLUCTUATION MEASUREMENT	15
6. ELECTROSTATIC DISCHARGE (ESD)	17
7. RADIATED SUSCEPTIBILITY (RS)	19
8. ELECTRICAL FAST TRANSIENT/BURST (EFT/B)	21
9. SURGE	23
10. CONDUCTED SUSCEPTIBILITY	25
11. POWER FREQUENCY MAGNETIC FIELD	27
12. VOLTAGE DIPS AND INTERRUPTION MEASUREMENT	28
13. MODIFICATION LIST FOR EMC COMPLYING TEST	30
14. TEST RESULTS	31
15. TELECOMMUNICATION PORT CONDUCTED EMISSIONS	32
16. RADIATED DISTURBANCE EMISSIONS	33
17. HARMONICS	48
18. VOLTAGE FLUCTUATIONS	49
19. ELECTROSTATIC DISCHARGE	50
20. RADIO-FREQUENCY, ELECTROMAGNETIC FIELD IMMUNITY	51
21. ELECTRICAL FAST TRANSIENTS/BURST IMMUNITY EMISSIONS	52
22. SURGE IMMUNITY	54
23. IMMUNITY TO CONDUCTIVE DISTURBANCE	55
24. POWER FREQUENCY MAGNETIC FIELD IMMUNITY	56
25. VOLTAGE DIPS, SHORT INTERRUPTION AND VOLTAGE VARIATION IMMUNIT	57
26. APPENDIX I – PHOTOGRAPHS OF TEST SETUP	58



## 1. GENERAL INFORMATION

### 1.1 TEST RESULT CERTIFICATION

**Applicant:** Danube Enterprise Co., Ltd

A2,NO.255,Fengren Rd., Renwu Shiang Kaohsiung County 814,  
Taiwan (R.O.C.)

**Manufacturer:** Danube Enterprise Co., Ltd

A2,NO.255,Fengren Rd., Renwu Shiang Kaohsiung County 814,  
Taiwan (R.O.C.)

**Equipment:** DC/DC Converter

**Sample received Date:**2006/11/14

**Detailed EUT Description:** See Item 1.2 of this report

EN55022:1998/A1:2000+A2:2003 ( class B)	IEC61 000-4-4:1995+A1:2000+A2:2001
EN61000-3-2:2000	IEC61000-4-5:1995+A1:2000
EN61000-3-3:1995/A1:2001	IEC61000-4-6:1996+A1:2000
EN55024:1998/A1:2001+A2:2003	IEC61 000-4-8:1993+A1:2000
IEC61000-4-2:1995+A1:1998+A2:2000	IEC61000-4-11:1994+A1:2000
IEC61000-4-3:1995+A2:2002	
<b>Deviation from Applicable Standard</b>	
<b>According to applicants declaration this EUT is a class B product, and to be market in general environment only.</b>	

The above equipment was tested by Compliance Certification Services Inc. for compliance with the requirements set forth in the EMC Directive 89/336/EEC and the technical standards mentioned above. The results of testing in this report apply only to the product/system, which was tested. Other similar equipment will not necessarily produce the same results due to production tolerance.



## 1.2 DESCRIPTION OF THE TESTED SAMPLES

<b>Product</b>	DC/DC Converter
<b>Model</b>	PU Series
<b>Housing Type</b>	Plastic case
<b>EUT power Rating</b>	Please refer to input voltage of table 1.2.1

### 1.2.1 Model Differences

Model Name	Difference
PUV-X1X2X3; PUV-X1X2X3-3K and PUV-X1X2X3-2W	V = Type of output voltage ( S = Single or D = Dual ) X1 = Input voltage ( Rang = 3.3 ; 5 ; 9 ; 12 or 24V ) X2 = Output voltage ( Rang = 3.3 ; 5 ; 9 ; 12 ; 15 ; +/- 5 ; +/- 12 or +/- 15 V ) X3 = Difference output voltage's pins. ** Detailed data please reference the appendix A file. **
PUD-X1X2X3X4	X1 = Input voltage ( Rang = 5 or 12V ) X2 = Output 1 voltage ( Rang = +5V ) X3= Output 2 voltage ( Rang = +3.3 ; +5 ; +9 ; +12 or +15V ) X4 = Difference output voltage's pins. ** Detailed data please reference the appendix A file. **

### 1.2.2 I/O port of the EUT

I/O port type	Q'ty	Tested with
N/A	N/A	N/A



## **1.3 TEST METHODOLOGY**

### **EUT SYSTEM OPERATION**

1. Turn on the power of all equipment.

### **DECISION OF FINAL TEST MODE**

1. The following test mode were scanned during the preliminary test:

Mode 1:The DC power to EUT Full Load

Mode 2:The DC power to EUT half Load

2. After the preliminary scan, the following test mode was found to produce the highest emission level.

Conduction: N/A

Radiation: Mode 1

Then, the EUT configuration and cable configuration of the above highest emission mode was chosen for all final test item



## 1.4 DESCRIPTION OF THE SUPPORT EQUIPMENTS

### Setup Diagram

See test photographs attached in appendix 1 for the actual connections between EUT and support equipment.

### Support Equipment

Peripherals Devices:

EMI							
No.	Equipment	Model	Serial No.	FCC ID/ BSMI ID	Trade name	Data Cable	Power Cord
1	DC Source	GPC-3030 DQ	C680186	N/A	GW	N/A	Unshielded 1.5M
2	Resister	N/A	N/A	N/A	N/A	N/A	Unshielded 0.5M

EMS							
No.	Equipment	Model	Serial No.	FCC ID/ BSMI ID	Trade name	Data Cable	Power Cord
1	DC Source	GPC-3030 DQ	C680186	N/A	GW	N/A	Unshielded 1.5M
2	Resister	N/A	N/A	N/A	N/A	N/A	Unshielded 0.5M

**Note:** All the above equipment /cable were placed in worse case position to maximize emission signals during emission test

**Grounding:** Grounding was in accordance with the manufacturer's requirement and conditions for the intended use.



## 2. INSTRUMENT AND CALIBRATION

### 2.1 MEASURING INSTRUMENT CALIBRATION

The measuring equipment utilized to perform the tests documented in the report has been calibrated once a year or in accordance with the manufacturer's recommendations, and is traceable to recognized national standards.

### 2.2 TEST AND MEASUREMENT EQUIPMENT

The following list contains measurement equipment used for testing. The equipment conforms to the requirement of CISPR 16-1, ANSI C63.2 and. Other required standards.

Calibration of all test and measurement, including any accessories that may effect such calibration, is checked frequently to ensure the accuracy. Adjustments are made and correction factors are applied in accordance with the instructions contained in the respective.

**TABLE 1 LIST OF TEST AND MEASUREMENT EQUIPMENT**

Instrument	Manufacturer	Model No.	Serial No.	Calibration Due Date
Test Receiver	AFJ	ER55C	55090502270	Apr.10.2007
Test Receiver	AFJ	ER55R	55300508277	May.18.2007
LISN	SCHAFFNER	NNB41	03/10026	Jun.04.2007
LISN	SCHAFFNER	NNB41	03/10015	Jun.04.2007
Power Filter	CORCOM	MR12030	N/A	N/A
Power Amplifier	SCHAFFNER	CBA9413B	4039	N/A
Bilog Antenna	SUNOL	JB1	A052104	SEP.25.2007
Antenna	EMC-PARTNER	MF-1000	739	OCT.11.2007
Turn table	EMCO	2080	9508-1805	N/A
Controller	EMCO	2090	9804-1328	N/A



RF Cable	MIYAZAKI	5D-F8	E037	Jun.01.2007
Thermo-Hygro meter	WISEWIND	N/A	N/A	OCT.11.2007
Decoupling network	Frankonia	M2+M3	A3011055	N/A
Decoupling network	Frankonia	RJ45	A3023009	N/A
EM Injection Clamp	FCC	F-203I-23MM	471	N/A
Signal Generator	IFR	2023A	202305/561	SEP.10.2007
POWER METER	BOONTON	4231A	110602	SEP.10.2007
Electric Field probe	ETS-LINDGREN	00029837	305650	MAY/29/2007
Amplifier	G.W	GAP-801	EF150001	Aug.03.2007
EMC Analyzer	AGILENT	E7401A	MY42000145	Jun.06.2007
Thermo-Hygro meter	WISEWIND	4-IN-1	0412	Apr.07.2007

Calibration interval of instruments listed above is one year



## **2.3 TEST PERFORMED**

Conducted emissions were investigated over the frequency range from 0.15MHz to 30MHz using a receiver which bandwidth is set at 9KHz.

Radiated emissions were investigated over the frequency range from 30MHz to 1000MHz using a receiver which bandwidth is set at 120KHz. Radiated measurement was performed at distance that from an antenna to EUT is 10meters.

## **2.4 APPENDIX**

### **APPENDIX A: MEASUREMENT PROCEDURE FOR MAIN POWER PORT CONDUCTED EMISSIONS**

The measurements are performed in a Global lab room,. The EUT was placed on non-conduction 1.0m x 1.5m table, which is 0.8 meters above an earth-grounded.

Power to the EUT was provided through the LISN which has the Impedance (50ohm/50uH) vs. Frequency Characteristic in accordance with the standard. Power to the LISNs were filtered to eliminate ambient signal interference and these filters were bonded to the ground plane. Peripheral equipment required to provide a functional system (support equipment) for EUT testing was powered from the second LISN through a ganged, metal power outlet box which is bonded to the ground plane at the LISN.

If the EUT is supplied with a flexible power cord, the power cord length in excess of the distance separating the EUT from the LISN shall be folded back and forth at the center of the lead so as to form a bundle not exceeding 40cm in length. If the EUT is provided with a permanently coiled power cord, bundling of the cord is not required. If the EUT is supplied without a power cord, the EUT shall be connected to the LISN by a power cord of the type specified by the manufacturer which shall not be longer than 1 meter. The excess power cord shall be bundled as described above. If a non-flexible power cord is provided with the EUT, it shall be cut to the length necessary to attach the EUT to the LISN and shall not be bundled.

The interconnecting cables were arranged and moved to get the maximum measurement. Both the line of power cord, hot and neutral, were measured.

The highest emissions were analyzed in details by operating the spectrum analyzer in fixed tuned mode to determine the nature of the emissions and to provide information which could be useful in reducing their amplitude.



## **APPENDIX B: TEST PROCEDURE FOR RADIATED EMISSIONS**

### **Preliminary Measurements in the Anechoic Chamber**

The radiated emissions are initially measured in the anechoic chamber at a measurement distance of 3 meters. Desktop EUT are placed on a wooden stand 0.8 meter in height. The measurement antenna is 3 meters from the EUT. The test setup in anechoic chamber is the same as open site. The turntable rotated 360(C. The antenna height is varied from 1-2.5m. The primary objective of the radiated measurements in the anechoic chamber is to identify the frequency spectrum in the absence of the electromagnetic environment existing on the open test site. The frequencies can then be pre-selected on the open test site to obtain the corresponding amplitude. The initial scan is made with the spectrum analyzer in automatic sweep mode. The spectrum peaks are then measured manually to determine the exact frequencies.

### **Measurements on the Open Site or Chamber**

The radiated emissions test will then be repeated on the open site or chamber to measure the amplitudes accurately and without the multiple reflections existing in the shielded room. The EUT and support equipments are set up on the turntable. Desktop EUT are set up on a wooden stand 0.8 meter above the ground.

For the initial measurements, the receiving antenna is varied from 1-4 meter height and is changed in the vertical plane from vertical to horizontal polarization at each frequency. Both reading are recorded with the quasi-peak detector with 120KHz bandwidth. For frequency between 30 MHz and 1000MHz, the reading is recorded with peak detector or quasi-peak detector.

At the highest amplitudes observed, the EUT is rotated in the horizontal plane while changing the antenna polarization in the vertical plane to maximize the reading. The interconnecting cables were arranged and moved to get the maximum measurement. Once the maximum reading is obtained, the antenna elevation and polarization will be varied between specified limits to maximize the readings.

### 3. CONDUCTED EMISSION MEASUREMENT

#### 3.1 TEST SET-UP

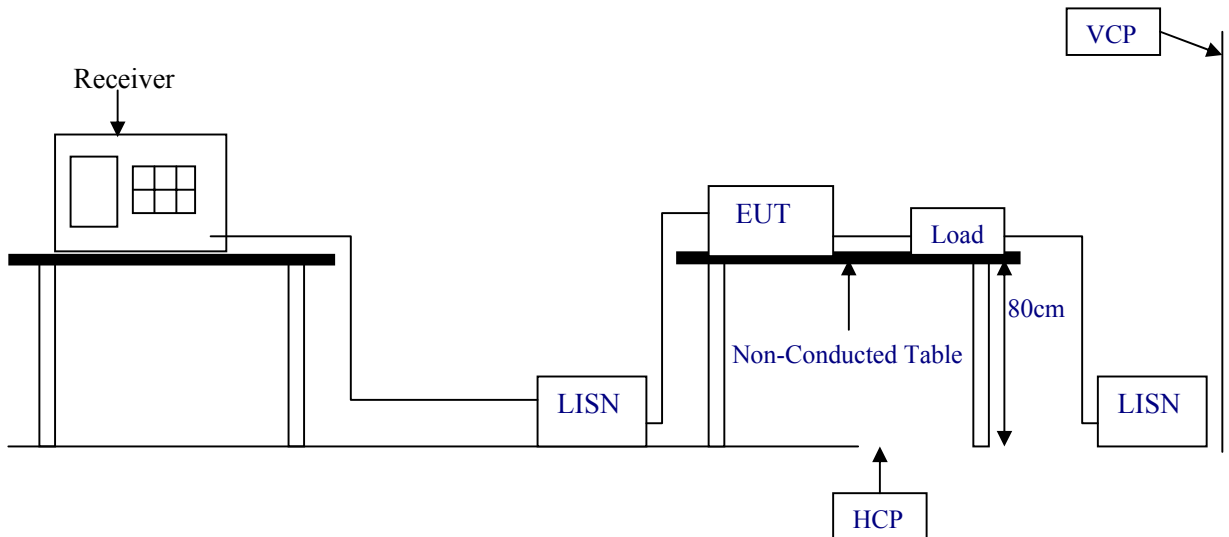

#### 3.2 LIMIT

Frequency MHz	Limit(dBμV)			
	Class A		Class B	
	Quasi Peak	Average	Quasi Peak	Average
0.15 ~ 0.50	79	66	66~56	56~46
0.50 ~ 5.0	73	60	56	46
5.0 ~30.0	73	60	60	50

Remark: In the above table, the tighter limit applies at the band edges.

#### 3.3 TEST PROCEDURE

The EUT and simulators are connected to the main power through a line impedance stabilization network (LISN). It provides a 50 ohm / 50 (H coupling impedance for the measuring equipment. The peripheral devices are also connected to the main power through a LISN that provides a 50 ohm / 50 (H coupling impedance with 50 ohm termination. (Please refers to the block diagram of the test setup and photograph.)

Both sides of AC line are checked for the maximum conducted emission interference. In order to find the maximum emissions, the relating positions of equipment and all of the interference cables must be changed according to EN 55022/1998 regulation: The measurement procedure on conducted emission interference.

The resolution bandwidth of the field strength meter is set at 9KHz



### **3.4 TEST SPECIFICATION**

According to the EN 55022/1998+A1:2000+A2:2003

## 4. RADIATED EMISSION MEASUREMENT

### 4.1 TEST SETUP

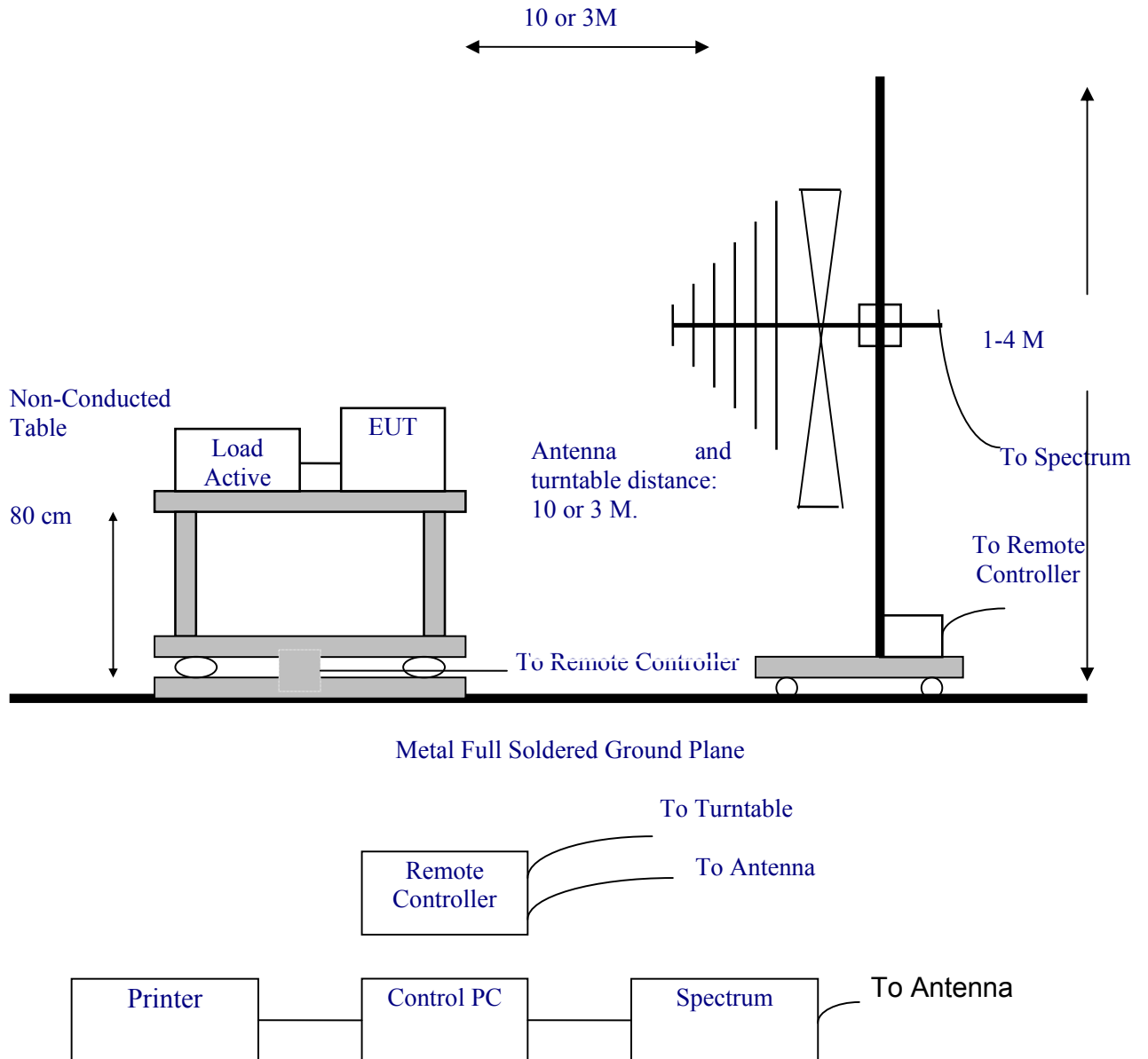



## 4.2 LIMIT

Frequency	Class A		Class B	
MHz	Distance (Meter)	Limit (dB $\mu$ V)	Distance (Meter)	Limit (dB $\mu$ V)
30 ~ 230	10	40	10	30
230 ~ 1000	10	47	10	37

Remark: In the above table, the tighter limit applies at the band edges

## 4.3 TEST PROCEDURE

The EUT and its simulators are placed on turn table, non-ducted and wooden, which is 0.8 meter above ground. The turn table rotates 360 degree to determine the position of the maximum emission level. The EUT was positioned such that distance from antenna to the EUT is 10 meters.

The antenna is moved up and down between 1 meter to 4 meter to receive the maximum emission level.

Both horizontal and vertical polarization of the antenna are set on measurement. In order to find the maximum emission, all of the interference cables must be manipulated according to EN 55022/1998 regulation: the test procedure of the radiated emission measurement.

The bandwidth set on the field strength is 120KHz when the frequency range is below 1GHz

## 4.4 TEST SPECIFICATION

According to EN 55022/1998+A1:2000+A2:2003



## 5. POWER HARMONIC AND VOLTAGE FLUCTUATION MEASUREMENT

### 5.1 TEST SETUP

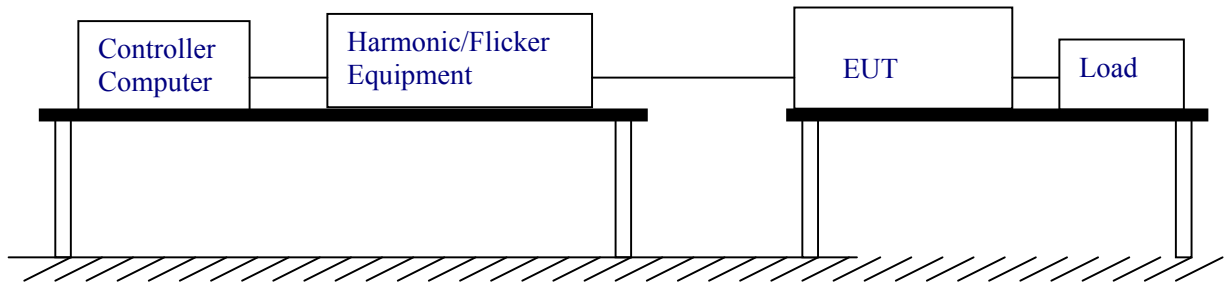

### 5.2 LIMIT OF HARMONIC CURRENT

Limit of Harmonic Currents

Harmonic Order	Maximum Permissible Harmonic Current (Ampere)	Harmonic Order	Maximum Permissible Harmonic Current (Ampere)
Odd Harmonic		Even Harmonic	
3	2.30	2	1.08
5	1.14	4	0.43
7	0.77	6	0.30
9	0.40	8( n ( 40	0.23 x 8/n
11	0.33		
13	0.21		
15( n ( 39	0.15 x 15/n		

### 5.3 TEST PROCEDURE

The EUT is supplied in series with power analyzer from a power source has the same normal voltage and frequency as the rated supply voltage and the equipment under test. The rated voltage at the supply voltage of EUT of 0.94 times and 1.06 times shall be performed.



## **5.4 TEST SPECIFICATION**

According to EN 61000-3-2/2000, EN 61000-3-3/1995+A1:2001

## 6. ELECTROSTATIC DISCHARGE (ESD)

### 6.1 TEST SETUP

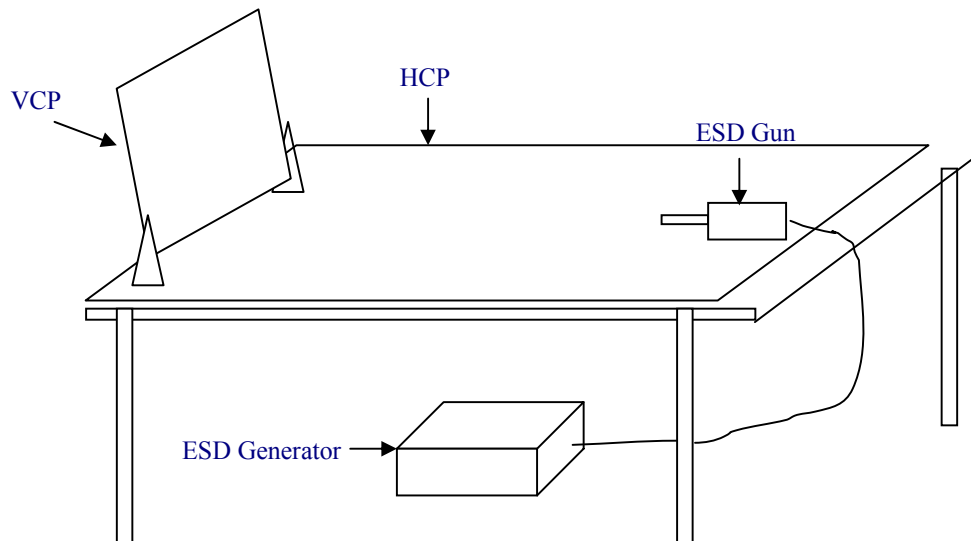

### 6.2 TEST LEVEL

Item	Test Specification	Unit	Performance Criteria
Enclosure Room	8 (Air Discharge)	KV (Charge Voltage)	B
Electrostatic Discharge	4 (Contact Discharge)		

### 6.3 TEST PROCEDURE

Direct applicant of discharge to the EUT:

Contact discharge was applied only to the conducted surfaces of the EUT.

Air discharge was applied only to the non-conductive surfaces of the EUT.

When the measurement was taken, The ESD discharger was performed in single discharge. For the single discharge time between successive single discharges will keep on one second. It was at least ten single discharges with positive and negative at the same selected pointed. The selected pointed, which was performed with electrostatic discharge, was marked on the red label on the EUT

Indirect applicant of discharge to the EUT

Vertical Coupling Plane (VCP)



The coupling plane, of dimensions 0.5m x 0.5m, is placed parallel to , and positioned at a distance 0.1m from, the EUT, with the discharge electrode touching the coupling plane.

The four faces of the EUT will be performed with electrostatic discharge. It was at least ten single discharges with positive and negative at the same selected point.

#### Horizontal Coupling Plane (HCP)

The coupling plane is placed under the EUT. The generator shall be positioned vertically at a distance of 0.1m from the EUT, with the discharge electrode touching the coupling.

The four faces of the EUT will be performed with electrostatic discharge. It was at least ten single discharges with positive and negative at the same selected pointed.

## **6.4 TEST SPECIFICATION**

According to EN 61000-4-2/1998+A2:2000

## 7. RADIATED SUSCEPTIBILITY (RS)

### 7.1 TEST SETUP

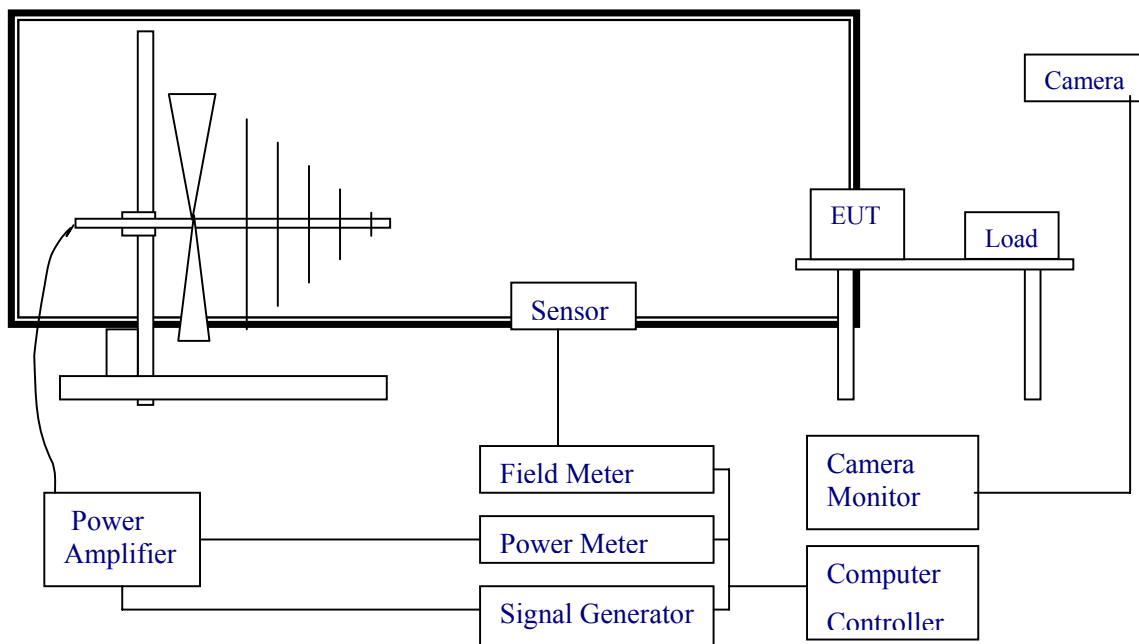

### 7.2 TEST LEVEL

Item	Test Specification	Unit	Performance Criteria
Radio –Frequency	80~1000	MHz	A
Electromagnetic Field	3	V/m (unmodulated, rms)	
Amplitude Modulated	80	%AM (1KHz)	



### **7.3 TEST PROCEDURE**

The EUT and load, which are placed on a wooden table that the height is 0.8 meter aboveground, are placed with one coincident with the calibration plane such that the distance from antenna to the EUT is 3 meters.

Both horizontal and vertical polarization of the antenna position and four sides of the EUT are set on measurement. In order to judge the EUT performance, a CCD camera is used to monitor the situation of EUT.

All the scanning conditions are as follows:

Condition of Test	Remarks
EN 61000-4-3/1995+A1:2002	
1. Field Strength	3V/M; Level 2
2. Radiated Signal	AM 80% modulated with 1KHz
3. Scanning Frequencies	80MHz ~ 1000MHz
4. Dwell Time	3 seconds
5. Frequency step size	1%
6. The rate of swept of frequency	$1.5 \times 10^{-3}$ decades/s

### **7.4 SPECIFICATION**

According to EN 61000-4-3:1995+A1:2002

## 8. ELECTRICAL FAST TRANSIENT/BURST (EFT/B)

### 8.1 TEST SETUP

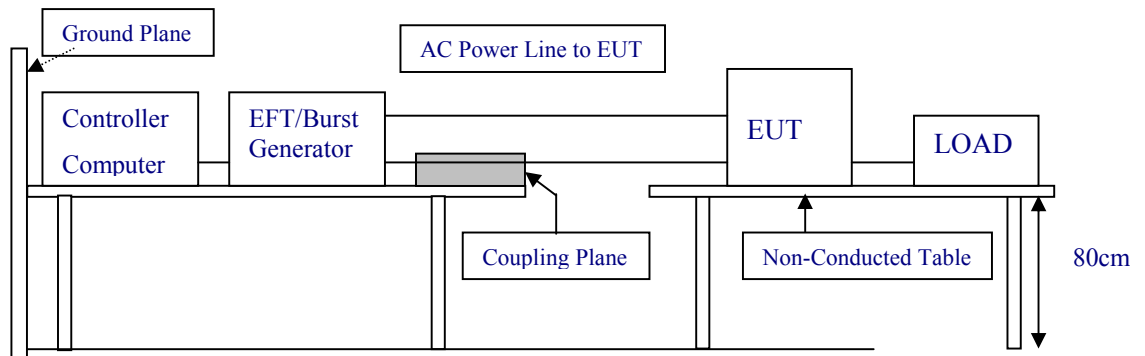

### 8.2 TEST PROCEDURE

The EUT and load are placed on a wooden table that is 0.8meter height above a metal ground plane dimension is 1m x 1m and thickness is at least 0.2mm. It also projected beyond the EUT by at lease 0.1meter on all sides.

For Input and Output AC power or DC Input and DC Output Power Ports:

The EUT is connected with the power mains through a coupling device that directly couples the EFT interference signal.

Each of the line and nature conductors is impressed with burst noise for 1 minute.

For Functional Earth Port:

The EUT is connected to the power mains through a coupling device that directly couples the EFT interference signal. The protective earth line (PE) is impressed with burst noise for 1 minute.

The length of power cord between the coupling device and the EUT shall be 1 meter.

For signal Lines and Control Lines Test:

The EFT interference signal is through a coupling clamp device couples to the signal and control lines of the EUT with burst noise for 1 minute.

### 8.3 TEST LEVEL

Item	Test Specification	Unit	Performance Criteria
Fast Transients Common Mode	0.5	KV (Peak)	B
	5/50	Tr/Ts (ns)	
	5	Rep. Frequency (KHz)	



## **8.4 TEST SPECIFICATION**

According to EN 61000-4-4/1995+A1:2000+A2:2001

## 9. SURGE

### 9.1 TEST SETUP

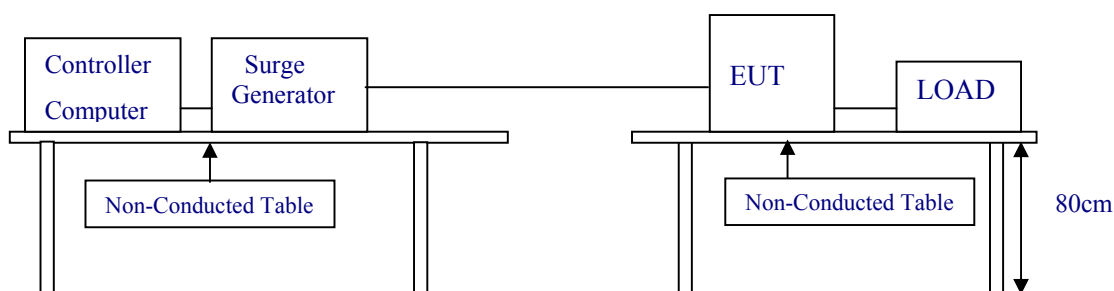

### 9.2 TEST LEVEL

Item	Test Specification	Unit	Performance Criteria
<b>Dc Input and DC Output Power Ports</b>			
Surge	1.2/50(8/20)	Tr/Ts ((s)	B
Line to Ground	±0.5	KV	
Line to Line	±0.5	KV	
<b>AC Input and Ac Output Power Ports</b>			
Surge	1.2/50(8/20)	Tr/Ts ((s)	B
Line to Ground	±2	KV	
Line to Line	±1	KV	

### 9.3 TEST PROCEDURE

The EUT and its load are placed on a table which is 0.8 meter height above a metal ground plane dimension is 1 meter x 1 meter and the thickness is 0.5 mm. It's also projected beyond the EUT at least 0.1 meter on all sides. The length of power cord between the coupling device and the EUT shall be 2meter or less.

For Input and Output AC Power or DC Input and Dc Output Power Ports:

The EUT is connected to the power mains through a coupling device that directly couples the Surge interference signal.

The Surge noise shall be applied synchronized to the voltage phase at 0(, 90(, 180(, 270( and the peak value of the AC voltage wave. (Positive and Negative)



Each of line-earth and line-line is impressed with a sequence of five surge voltages with interval of 1 minute.

#### **9.4 TEST SPECIFICATION**

According to EN 61000-4-5/1995 +A1:2000

## 10. CONDUCTED SUSCEPTIBILITY

### 10.1 TEST SETUP

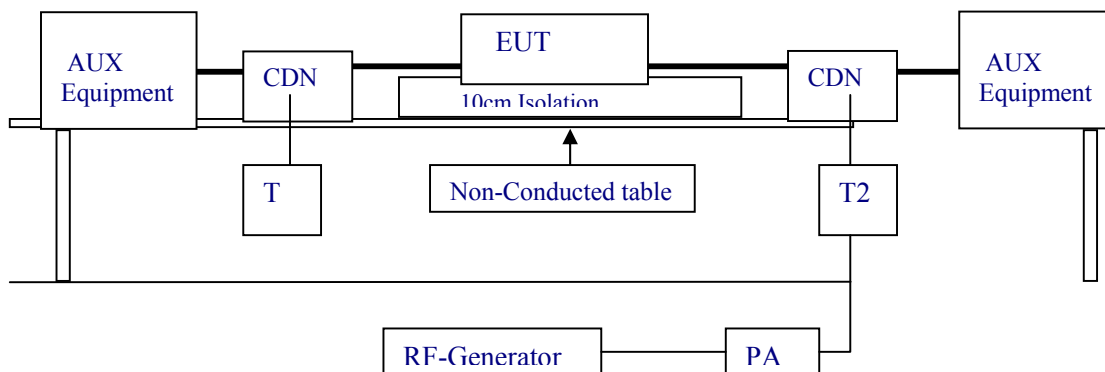

### 10.2 TEST LEVEL

Item	Test Specification	Unit	Performance Criteria
Ports for Signal Lines and Data Buses, not involved in process control, etc.			
Radio-Frequency	0.15 ~ 80	MHz	A
Common Mode	3	V (rms, Unmodulated)	
Amplitude Modulated	80	%AM (1KHz)	
	150	Source Impedance	
Ac Input and AC Output and DC Input and DC output Ports and Functional Earth Ports			
Radio-Frequency	0.15 ~ 80	MHz	
Common Mode	3	V (rms, Unmodulated)	A
Amplitude Modulated	80	%AM (1KHz)	
	150	Source Impedance	

### 10.3 TEST PROCEDURE

The EUT are placed on a table which is 0.8meter height and a ground reference plane on the table, the EUT are placed upon table and use a 10cm insulation between the EUT and ground reference plane.

For AC Input and AC Output Power or DC Input and DC Output Power Ports

The EUT is connected to the power mains through a coupling and decoupling networks for power supply lines. It also directly couples the disturbance signal into EUT.

Use CDN-M2 for two wires or CDN-3 for three wires.

For Signal Lines Lines and Control Lines Test:

The disturbance signal is through a coupling and decoupling networks (CDN) or EM-clamp device couples to the signal and control lines of the EUT.

All scanning frequencies conditions are as following:



---

Condition of Test	Remarks
EN 61000-4-6/1996+A1:2000	
1. Field Strength	3V/M; Level 2
2. Radiated Signal	AM 80% modulated with 1KHz
3. Scanning Frequencies	0.15MHz ~ 80MHz
4. Dwell Time	3 seconds
5. Frequency step size $\Delta f$	1%
6. The rate of swept of frequency	$1.5 \times 10^{-3}$ decades/s

## 10.4 TEST SPECIFICATION

According to EN 61000-4-6/1996+A1:2000

## 11. POWER FREQUENCY MAGNETIC FIELD

### 11.1 TEST SETUP

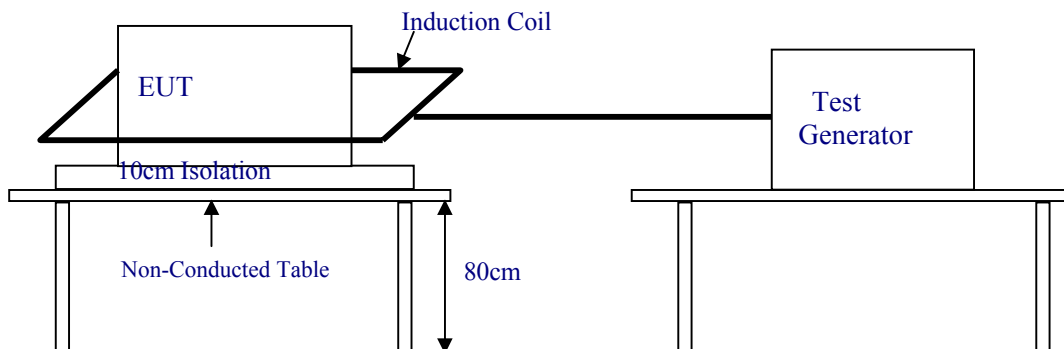

### 11.2 TEST LEVEL

Item	Test Specification	Unit	Performance Criteria
Power-Frequency	Hz	50	A
Magnetic Field	A/M	3	

### 11.3 TEST PROCEDURE

The EUT and its load are placed on a table that is 0.8 meter above the metal ground plane dimension is at least 1 meter x 1 meter. The test magnetic field shall be placed at least than 3 meter distance from the induction coil.

The test magnetic field shall be applied by the immersion method to the EUT. The induction coil shall be rotated by 90° in order to expose the EUT to the test field with different orientation (X, Y, Z orientation).

### 11.4 TEST SPECIFICATION

According to EN 61000-4-8/1993+A1:2000

## 12. VOLTAGE DIPS AND INTERRUPTION MEASUREMENT

### 12.1 TEST SETUP

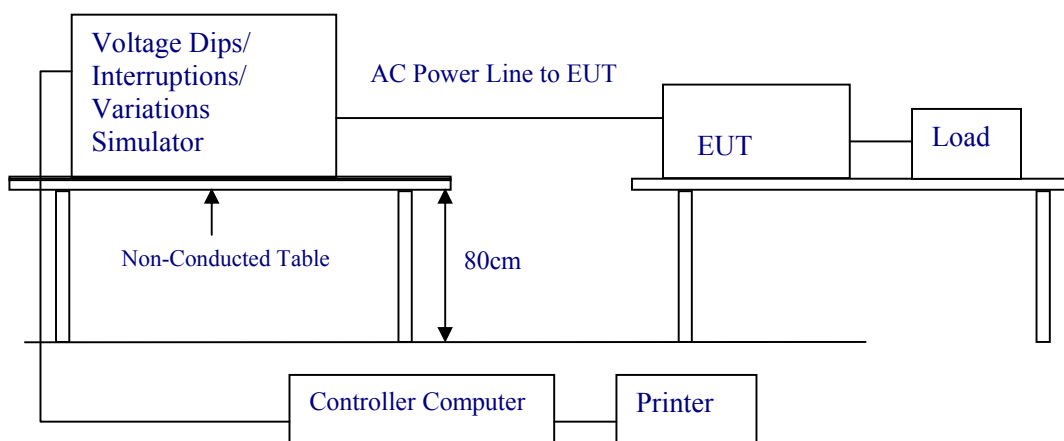

### 12.2 TEST LEVEL

Item	Test Specification	Unit	Performance Criteria
Voltage Dips	% Reduction	30	B
	ms	10	
	% Reduction	60	
	ms	100	
	% Reduction	>95%	
Voltage Interruption	ms	5000	C

### 12.3 TEST PROCEDURE

The EUT and its load are placed on a wooden table which is 0.8 meter above a metal ground plane which dimension is 1 meter x 1 meter, the thickness is 0.65mm. It projected beyond the EUT by at least 0.1 meter on all sides. The power cord shall be used the shortest power cord as specified by the manufacturer.

For Voltage Dips / Interruption Test:



The EUT is connected to the power mains through a coupling device that directly couples to the Voltage Dips and Interruption Generator.

The EUT shall be tested for 30% voltage dips of supplied voltage and duration time is 10ms, for 60% voltage dips of supplied voltage and duration time is 100ms with a sequence of three voltage dips with intervals of 10 seconds, and for 95% voltage interruption of supplied voltage and the duration time is 5000ms with a sequence of three voltage interruptions with intervals of 10 seconds.

Voltage phase shifting are shall occur at 0°, 45°, 90°, 135°, 180°, 225°, 270°, 315° of the voltage.

## **12.4 TEST SPECIFICATION**

According to EN 61000-4-11/1994+A1:2000



### 13. MODIFICATION LIST FOR EMC COMPLYING TEST

The modification is solely made by the applicant.

Appendix

Appendix A: Summary of Test Result

Appendix B: The test photograph of EUT

Appendix C: The Detail Photograph of EUT

Appendix A: Summary of Test Result

\*\*\*\*\* EMC Test Result: The EUT has been pass the all measurements. \*\*\*\*\*

The uncertainty is calculated in accordance with CISPR16-4-2, the total uncertainty for this test is as follows:

#### Uncertainty of Conducted Emission Measurement

Contribution	Probability Distribution	150KHz – 30MHz
Receiver reading	Normal (k=2)	±0.2
Cable loss	Normal (k=2)	±0.2
AMN insertion loss	Rectangular	±0.2
RCV/SPA specification	Rectangular	±0.9
combined standard uncertainty Ue(y)	normal	±1.0
Measuring uncertainty for a level of confidence of 95% U=2Ue(y)	normal (k=2)	±2.0

#### Uncertainty of Radiated Emission Measurement

Contribution	Probability Distribution	30MHz~1GHz
Receiver reading	Normal (k=2)	±0.5
Cable loss calibration	Normal (k=2)	±0.3
Antenna factor calibration	Rectangular	±1.5
Pre Amplifier Gain calibration	Rectangular	±0.5
RCV/SPA specification	Rectangular	±0.9
combined standard uncertainty Ue(y)	normal	±1.1
Measuring uncertainty for a level of confidence of 95% U=2Ue(y)	normal (k=2)	±2.2



## **14. TEST RESULTS**

### **14.1 EMI RECEIVER/SPECTRUM ANALYZER CONFIGURATION (FOR THE FREQUENCIES TESTED)**

Frequency Range:	150KHz--30MHz
Detector Function:	Quasi-Peak / Average Mode
Resolution Bandwidth:	9KHz

### **14.2 TEST RESULT:**

The EUT's power is from DC source , so it is not necessary to be tested.



## **15. TELECOMMUNICATION PORT CONDUCTED EMISSIONS**

### **15.1 CONFIGURATION AND PROCEDURE EUT CONFIGURATION**

The EUT was set up on the non-conductive table that is 1.0 by 1.5 meter, 80cm above ground. The wall was 40cm to the rear of the EUT. The excess length of the power cord was folded back and forth at the center of the lead to form a bundle 30cm to 40cm in length. The distance between EUT and CDN is 80cm. CDN is connected to the reference ground plane.

Any changes made to the configuration, or modifications made to the EUT, during testing are noted in the following test record.

### **15.2 TEST PROCEDURE**

The system was set up as described above, with the EMI diagnostic software running.

The content of the software consist of both periodic and pseudo-random messages.

The effect of varying the position of the interface cables has been investigated to find the configuration that produces maximum emission.

The highest emissions were analyzed in details by operating the spectrum analyzer in fixed tuned mode to determine the nature of the emissions and to provide information which could be useful in reducing their amplitude.

### **15.3 EMI RECEIVER/SPECTRUM ANALYZER CONFIGURATION (FOR THE FREQUENCIES TESTED)**

Frequency Range:	150KHz--30MHz
Detector Function:	Quasi-Peak / Average Mode
Resolution Bandwidth:	9KHz

\*\*Remarks: This EUT has no telecommunication ports, so it is not necessary to be tested.



## **16. RADIATED DISTURBANCE EMISSIONS**

### **16.1 URATION AND PROCEDURE**

#### **16.2.1 EUT Configuration**

The equipment under test was set up on a non-conductive table 80cm above ground, on a open field or chamber. The excess length of the power cord was folded back and forth at the center of the lead to form a bundle 30cm to 40cm in length.

Any changes made to the configuration, or modifications made to the EUT, during testing are noted in the following test record.

If EUT has an extra auxiliary DC outlet which can provide power to an external monitor, all measurements will be made with the monitor power from EUT-mounted DC outlet and then from floor-mounted DC outlet.

#### **16.2.2 Test Procedure**

The system was set up as described above, with the EMI diagnostic software running. The maximum emission was measured by varying the height of antenna and then by rotating the turntable. Both polarization of antenna, horizontal and vertical, were measured.

The highest emissions between 30 MHz to 1000 MHz were analyzed in details by operating the spectrum analyzer and/or EMI receiver in quasi-peak mode to determine the precise amplitude of the emissions. While doing so, the interconnecting cables and major parts of the system were moved around, the antenna height was varied between one and four meters, its polarization was varied between vertical and horizontal, and the turntable was slowly rotated, to maximize the emission.

#### **16.2.3 Spectrum Analyzer Configuration (for the frequencies tested)**

Frequency Range:	30MHz--1000MHz
Detector Function:	Quasi-Peak Mode
Resolution Bandwidth:	120KHz



**16.2 TEST DATA:**

**TABLE 4.2.1 RADIATED EMISSIONS (HORIZONTAL)**

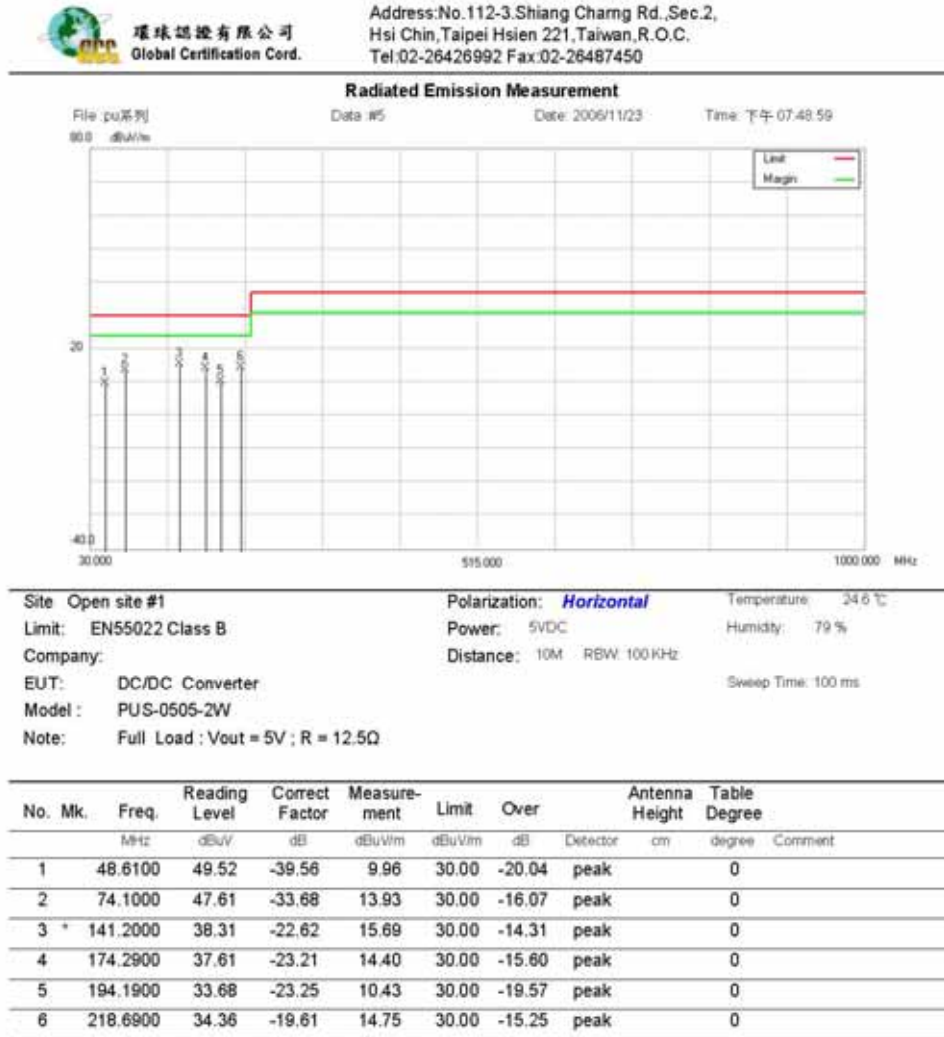

\*:Maximum data    x:Over limit    f:over margin

•Reference Only

Receiver:

Spectrum Analyzer: FSP3

Antenna: factor-060920

Engineer Signature: Daniel

Amplifier:

File :pu系列\Data :#5

Page: 1



環球認證有限公司  
Global Certification Cord.

Address:No.112-3,Shiang Charng Rd.,Sec.2,  
Hsi Chin,Taipei Hsien 221,Taiwan,R.O.C.  
Tel:02-26426992 Fax:02-26487450

**Radiated Emission Measurement**



Site: Open site #1	Polarization: <b>Horizontal</b>	Temperature: 24.6 °C
Limit: EN55022 Class B	Power: 5VDC	Humidity: 79 %
Company:	Distance: 10M RBW: 100 KHz	Sweep Time: 100 ms
EUT: DC/DC Converter		
Model: PUD-0505-3K		
Note: Full Load : Vout1 =+ 5V ; Vout2 =-5V ; R1& R2= 50Ω		

No.	Mk.	Freq.	Reading Level	Correct Factor	Measurement	Limit	Over	Antenna Height	Table Degree
		MHz	dBuV	dB	dBuV/m	dBuV/m	dB	cm	degree
1		51.3600	48.69	-38.48	10.21	30.00	-19.79	peak	0
2		79.6100	43.29	-33.43	9.86	30.00	-20.14	peak	0
3		122.1800	36.94	-25.89	11.05	30.00	-18.95	peak	0
4	*	146.5900	38.11	-22.28	15.83	30.00	-14.17	peak	0
5		187.6100	34.16	-23.43	10.73	30.00	-19.27	peak	0
6		249.2600	37.60	-15.07	22.53	37.00	-14.47	peak	0

\*:Maximum data x:Over limit !:over margin

●Reference Only

Receiver:  
Antenna: factor-060920  
Amplifier:

Spectrum Analyzer: FSP3  
Engineer Signature: Daniel

File :pu系列\Data :#2

Page: 1



環球認證有限公司  
Global Certification Cord.

Address:No.112-3,Shiang Charng Rd.,Sec.2,  
Hsi Chin,Taipei Hsien 221,Taiwan,R.O.C.  
Tel:02-26426992 Fax:02-26487450

**Radiated Emission Measurement**

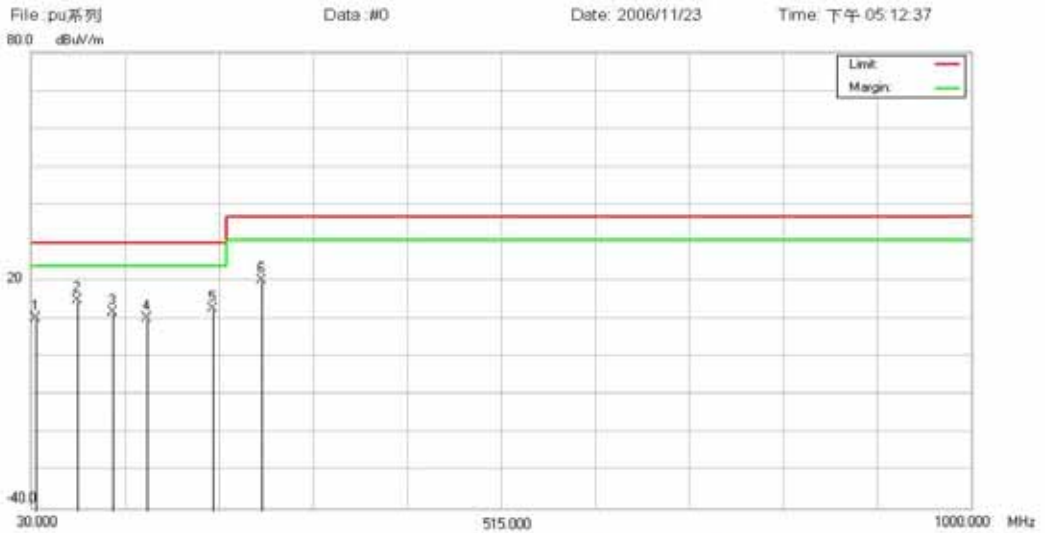

Site: Open site #1	Polarization: <b>Horizontal</b>	Temperature: 24.6 °C
Limit: EN55022 Class B	Power: 5VDC	Humidity: 79 %
Company:	Distance: 10M RBW: 100 KHz	Sweep Time: 100 ms
EUT: DC/DC Converter		
Model: PUS-0505A		
Note: Full Load : Vout = 5V ; R = 25Ω		

No.	Mk.	Freq.	Reading Level	Correct Factor	Measurement	Limit	Over	Antenna Height	Table Degree
		MHz	dBuV	dB	dBuV/m	dBuV/m	dB	cm	degree
1		34.6900	42.69	-32.52	10.17	30.00	-19.83 peak		0
2	*	78.2600	48.67	-33.55	15.12	30.00	-14.88 peak		0
3		114.3800	39.68	-27.84	11.84	30.00	-18.16 peak		0
4		149.6900	32.69	-22.33	10.36	30.00	-19.64 peak		0
5		218.0000	32.36	-19.71	12.65	30.00	-17.35 peak		0
6		267.3000	36.10	-15.96	20.14	37.00	-16.86 peak		0

\*:Maximum data x:Over limit !:over margin •Reference Only

Receiver:  
Antenna: factor-060920  
Amplifier:

Spectrum Analyzer: FSP3  
Engineer Signature: Daniel

File :pu系列\Data :#0

Page: 1



環球認證有限公司  
Global Certification Cord.

Address:No.112-3,Shiang Charng Rd.,Sec.2,  
Hsi Chin,Taipei Hsien 221,Taiwan,R.O.C.  
Tel:02-26426992 Fax:02-26487450

**Radiated Emission Measurement**

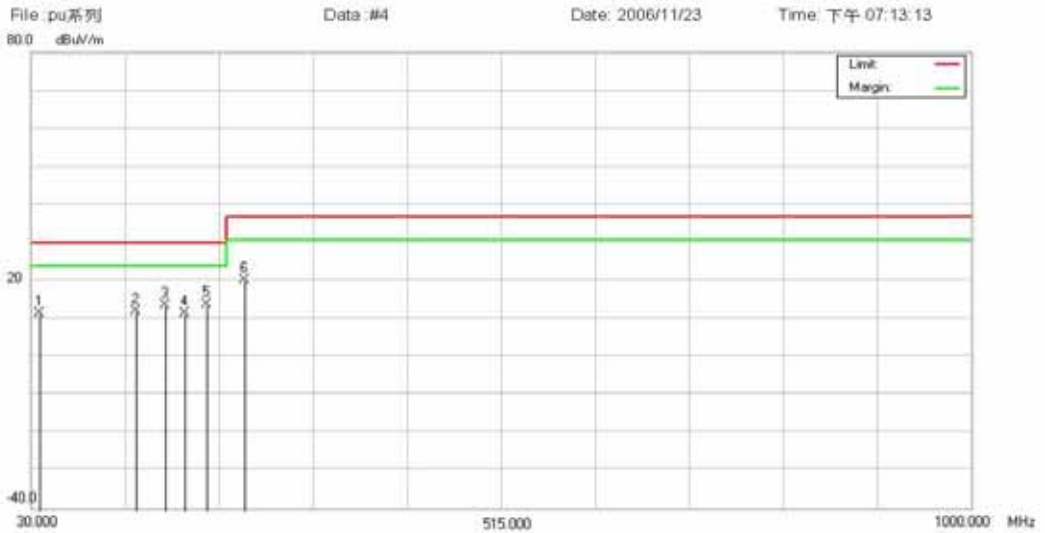

Site: Open site #1	Polarization: <b>Horizontal</b>	Temperature: 24.6 °C
Limit: EN55022 Class B	Power: 12VDC	Humidity: 79 %
Company:	Distance: 10M RBW: 100 KHz	Sweep Time: 100 ms
EUT: DC/DC Converter		
Model: PUS-1205-3K		
Note: Full Load : Vout = 5V ; R = 25Ω		

No.	Mk.	Freq.	Reading Level	Correct Factor	Measurement	Limit	Over	Antenna Height	Table Degree
		MHz	dBuV	dB	dBuV/m	dBuV/m	dB	cm	degree
1		39.6800	51.69	-40.26	11.43	30.00	-18.57 peak		0
2		137.6900	34.68	-22.76	11.92	30.00	-18.08 peak		0
3		168.9700	36.39	-22.94	13.45	30.00	-16.55 peak		0
4		188.8800	34.69	-23.28	11.41	30.00	-18.59 peak		0
5	*	211.6800	34.36	-20.63	13.73	30.00	-16.27 peak		0
6		249.5900	35.26	-15.09	20.17	37.00	-16.83 peak		0

\*:Maximum data x:Over limit !:over margin

●Reference Only

Receiver:  
Antenna: factor-060920  
Amplifier:

Spectrum Analyzer: FSP3  
Engineer Signature: Daniel

File :pu系列\Data #4

Page: 1



環球認證有限公司  
Global Certification Cord.

Address:No.112-3,Shiang Chang Rd.,Sec.2,  
Hsi Chin,Taipei Hsien 221,Taiwan,R.O.C.  
Tel:02-26426992 Fax:02-26487450

**Radiated Emission Measurement**

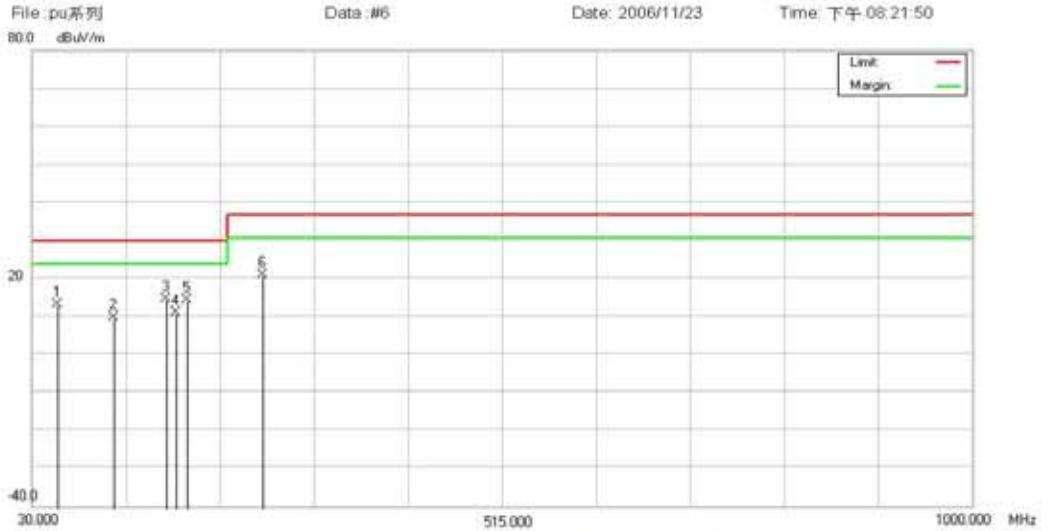

Site: Open site #1      Polarization: **Horizontal**      Temperature: 24.6 °C  
 Limit: EN55022 Class B      Power: 12VDC      Humidity: 79 %  
 Company:      Distance: 10M RBW: 100 KHz  
 EUT: DC/DC Converter      Sweep Time: 100 ms  
 Model: PUD-1212-2W  
 Note: Full Load : Vout1 = +12V ; Vout2 = -12V ; R1 & R2 = 142.8Ω

No.	Mk.	Freq.	Reading Level	Correct Factor	Measurement	Limit	Over	Antenna Height	Table Degree	
		MHz	dBuV	dB	dBuV/m	dBuV/m	dB	cm	degree	Comment
1		57.1600	48.19	-34.97	13.22	30.00	-16.78	peak	0	
2		114.6800	37.69	-27.77	9.92	30.00	-20.08	peak	0	
3	*	168.1900	37.68	-22.90	14.78	30.00	-15.22	peak	0	
4		178.6900	34.16	-23.09	11.07	30.00	-18.93	peak	0	
5		190.4900	37.61	-23.16	14.45	30.00	-15.55	peak	0	
6		268.1600	37.18	-16.05	21.13	37.00	-15.87	peak	0	

\*:Maximum data    x:Over limit    !:over margin

●Reference Only

Receiver:

Spectrum Analyzer: FSP3

Antenna: factor-060920

Engineer Signature: Daniel

Amplifier:

File :pu系列\Data :#6

Page: 1



環球認證有限公司  
Global Certification Cord.

Address:No.112-3,Shiang Chang Rd.,Sec.2,  
Hsi Chin,Taipei Hsien 221,Taiwan,R.O.C.  
Tel:02-26426992 Fax:02-26487450

**Radiated Emission Measurement**

File :pu系列      Data :#9      Date: 2006/11/23      Time: 下午 09:10:42

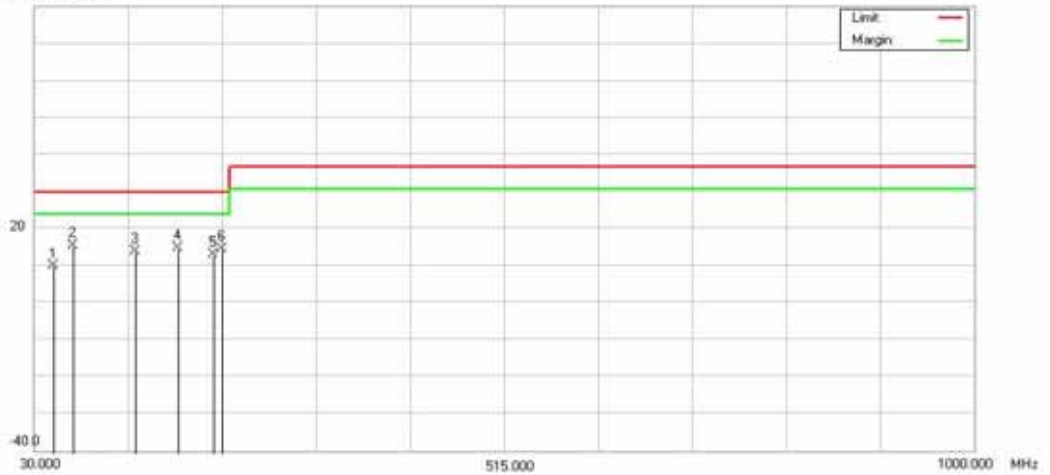

Site : Open site #1	Polarization: <b>Horizontal</b>	Temperature: 24.6 °C
Limit: EN55022 Class B	Power: 24VDC	Humidity: 79 %
Company:	Distance: 10M RBW: 100 KHz	Sweep Time: 100 ms
EUT: DC/DC Converter		
Model : PUS-2405-2W		
Note: Full Load : Vout = 5V ; R1 = 12.5Ω		

No.	Mk.	Freq. MHz	Reading Level dBuV	Correct Factor dB	Measurement dBuV/m	Limit dBuV/m	Over dB	Detector	Antenna Height cm	Table Degree	Comment
1		49.5800	49.36	-39.23	10.13	30.00	-19.87	peak		0	
2	*	69.1900	47.61	-31.97	15.64	30.00	-14.36	peak		0	
3		133.6400	37.26	-23.03	14.23	30.00	-15.77	peak		0	
4		178.4900	38.19	-23.10	15.09	30.00	-14.91	peak		0	
5		216.1900	33.16	-19.99	13.17	30.00	-16.83	peak		0	
6		223.4900	33.26	-18.65	14.61	30.00	-15.39	peak		0	

\*:Maximum data    x:Over limit    !:over margin

●Reference Only

Receiver:

Spectrum Analyzer: FSP3

Antenna: factor:060920

Engineer Signature: Daniel

Amplifier:

File :pu系列\Data :#9

Page : 1



環球認證有限公司  
Global Certification Cord.

Address:No.112-3,Shiang Chang Rd.,Sec.2,  
Hsi Chin,Taipei Hsien 221,Taiwan,R.O.C.  
Tel:02-26426992 Fax:02-26487450

**Radiated Emission Measurement**

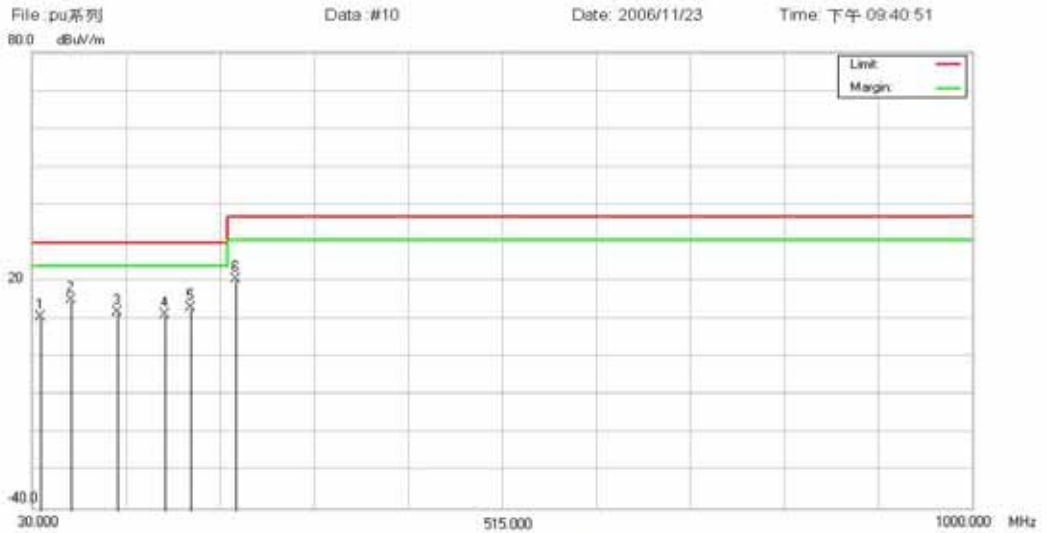

Site: Open site #1 Polarization: **Horizontal** Temperature: 24.6 °C  
 Limit: EN55022 Class B Power: 24VDC Humidity: 79 %  
 Company: Distance: 10M RBW: 100 KHz  
 EUT: DC/DC Converter Sweep Time: 100 ms  
 Model : PUD-2415-2W  
 Note: Full Load ; Vout1; +15VDC ; Vout2; -15VDC R1& R2 ; 223.9Ω

No.	Mk.	Freq.	Reading Level	Correct Factor	Measurement	Limit	Over	Antenna Height	Table Degree		
		MHz	dBuV	dB	dBuV/m	dBuV/m	dB	Detector	cm	degree	Comment
1		38.6900	49.16	-38.75	10.41	30.00	-19.59	peak		0	
2	*	69.1900	47.10	-31.97	15.13	30.00	-14.87	peak		0	
3		118.1700	38.60	-26.82	11.78	30.00	-18.22	peak		0	
4		167.4100	34.11	-22.86	11.25	30.00	-18.75	peak		0	
5		193.1400	36.10	-23.23	12.87	30.00	-17.13	peak		0	
6		241.3000	35.87	-15.46	20.41	37.00	-16.59	peak		0	

\*:Maximum data x:Over limit !:over margin

●Reference Only

Receiver:

Spectrum Analyzer: FSP3

Antenna: factor-060920

Engineer Signature: Daniel

Amplifier:

File :pu系列\Data :#10

Page : 1



環球認證有限公司  
Global Certification Cord.

Address:No.112-3,Shiang Chang Rd.,Sec.2,  
Hsi Chin,Taipei Hsien 221,Taiwan,R.O.C.  
Tel:02-26426992 Fax:02-26487450

**Radiated Emission Measurement**

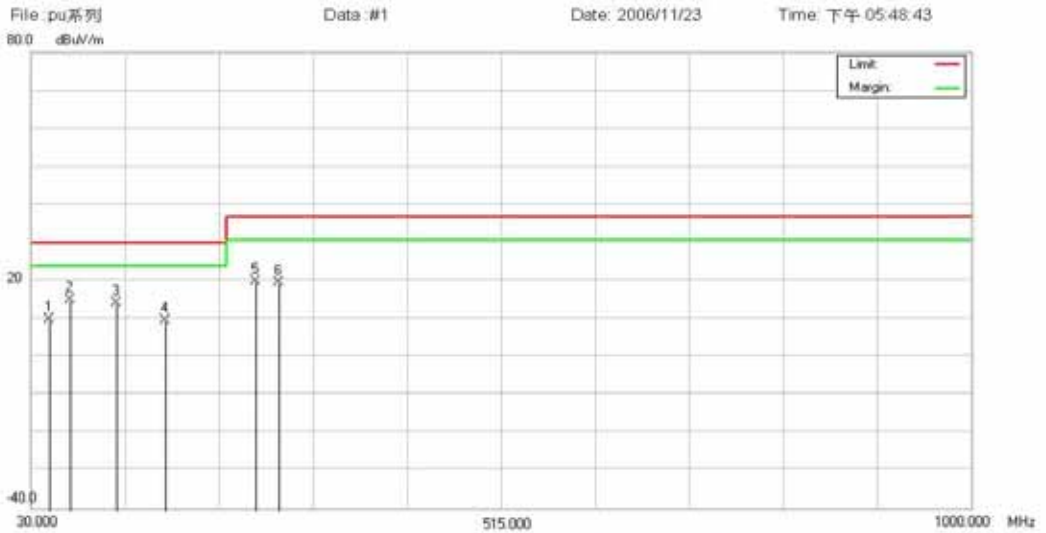

Site: Open site #1      Polarization: **Horizontal**      Temperature: 24.6 °C  
 Limit: EN55022 Class B      Power: 12VDC      Humidity: 79 %  
 Company:      Distance: 10M RBW: 100 KHz  
 EUT: DC/DC Converter      Sweep Time: 100 ms  
 Model: PUD-120512  
 Note: Full Load : Vout1 = + 5V ; Vout2 = +12V ; R1= 50Ω ; R2 = 285.7Ω

No.	Mk.	Freq.	Reading Level	Correct Factor	Measurement	Limit	Over	Antenna Height	Table Degree	
		MHz	dBuV	dB	dBuV/m	dBuV/m	dB	Detector	cm	degree
1		48.2700	49.68	-39.68	10.00	30.00	-20.00	peak		0
2	*	69.3700	47.36	-32.19	15.17	30.00	-14.83	peak		0
3		117.3600	41.30	-27.04	14.26	30.00	-15.74	peak		0
4		168.3100	32.68	-22.91	9.77	30.00	-20.23	peak		0
5		261.3700	35.69	-15.69	20.00	37.00	-17.00	peak		0
6		284.4100	34.29	-14.70	19.59	37.00	-17.41	peak		0

\*:Maximum data    x:Over limit    !:over margin

●Reference Only

Receiver:

Spectrum Analyzer: FSP3

Antenna: factor-060920

Engineer Signature: Daniel

Amplifier:

File :pu系列\Data :#1

Page : 1



**TABLE 4.2.2 RADIATED EMISSIONS (VERTICAL)**



Address:No.112-3,Shiang Charng Rd.,Sec.2,  
Hsi Chin,Taipei Hsien 221,Taiwan,R.O.C.  
Tel:02-26426992 Fax:02-26487450

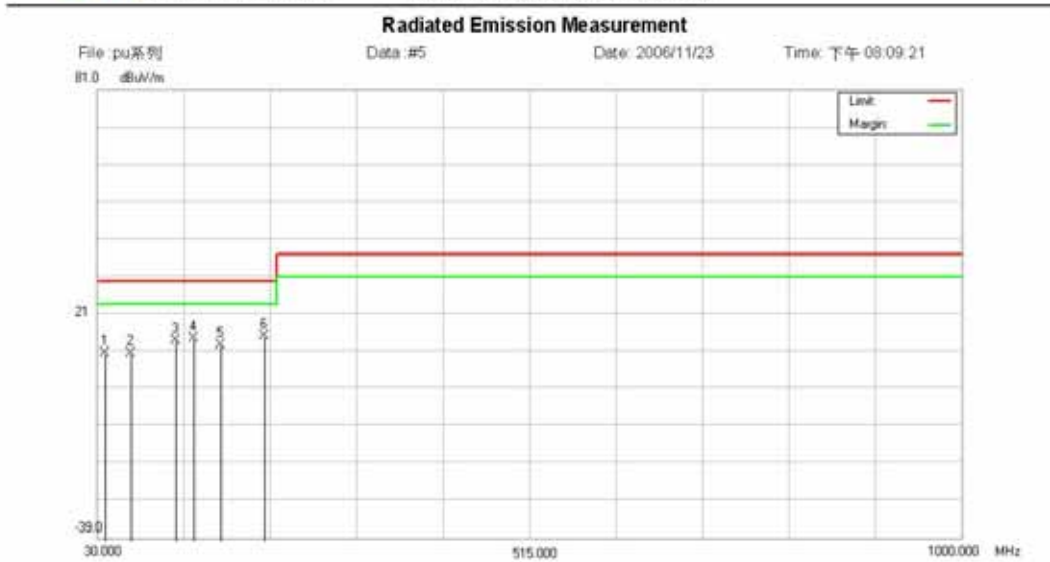

Site: Open site #1 Limit: EN55022 Class B Company: EUT: DC/DC Converter Model: PUS-0505-2W Note: Full Load ; Vout ; 5V ; R ; 12.5Ω	Polarization: <b>Vertical</b> Power: 5VDC Distance: 10M    RBW: 100 KHz Temperature: 24.6 °C Humidity: 79 % Sweep Time: 100 ms
---	---

No.	Mk.	Freq.	Reading Level	Correct Factor	Measurement	Limit	Over	Antenna Height	Table Degree	
		MHz	dBuV	dB	dBuV/m	dBuV/m	dB	cm	degree	Comment
1		39.6700	44.39	-33.82	10.57	30.00	-19.43	peak	0	
2		67.1900	48.69	-38.00	10.69	30.00	-19.31	peak	0	
3		117.6900	36.79	-22.98	13.81	30.00	-16.19	peak	0	
4	*	137.4800	36.69	-22.05	14.64	30.00	-15.36	peak	0	
5		169.6800	31.16	-18.44	12.72	30.00	-17.28	peak	0	
6		216.3700	36.16	-21.10	15.06	30.00	-14.94	peak	0	

\*:Maximum data    x:Over limit    !:over margin

●Reference Only

Receiver:  
Antenna: factor-060920  
Amplifier:

Spectrum Analyzer: FSP3  
Engineer Signature: **Daniel**

File :pu系列\Data :#5

Page: 1



環球認證有限公司  
Global Certification Cord.

Address:No.112-3,Shiang Chang Rd.,Sec.2,  
Hsi Chin,Taipei Hsien 221,Taiwan,R.O.C.  
Tel:02-26426992 Fax:02-26487450

**Radiated Emission Measurement**

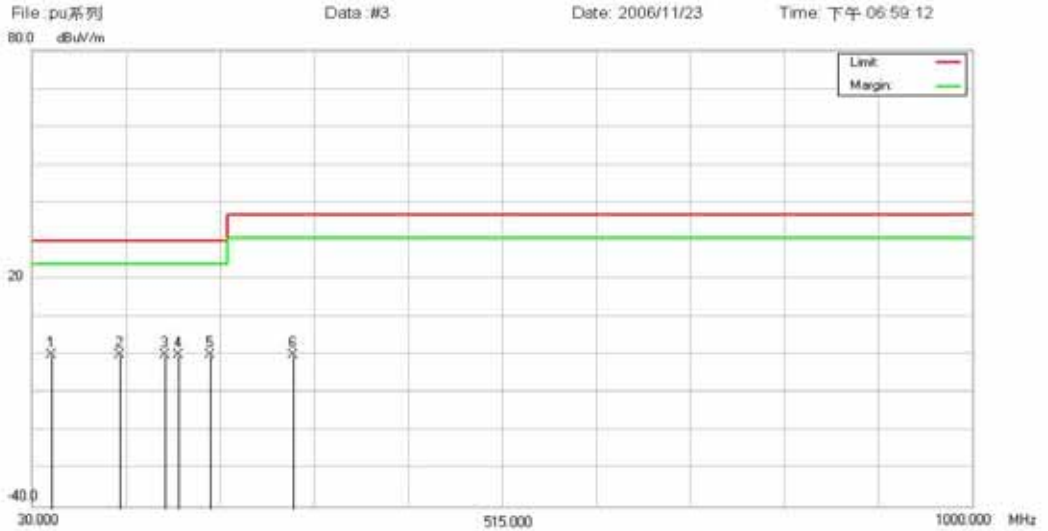

Site: Open site #1      Polarization: **Vertical**      Temperature: 24.6 °C  
 Limit: EN55022 Class B      Power: 5VDC      Humidity: 79 %  
 Company:      Distance: 10M RBW: 100 KHz  
 EUT: DC/DC Converter      Sweep Time: 100 ms  
 Model : PUD-0505-3K  
 Note: Full Load ; Vout1 ;+ 5V ; Vout2 ;-5V ; R1 & R2; 50Ω

No.	Mk.	Freq.	Reading Level	Correct Factor	Measurement	Limit	Over	Antenna Height	Table Degree		
		MHz	dBuV	dB	dBuV/m	dBuV/m	dB	Detector	cm	degree	Comment
1	*	49.8700	33.96	-33.96	0.00	30.00	-30.00	peak		0	
2		119.8900	22.81	-22.81	0.00	30.00	-30.00	peak		0	
3		167.5900	18.67	-18.67	0.00	30.00	-30.00	peak		0	
4		179.6800	19.30	-19.30	0.00	30.00	-30.00	peak		0	
5		213.3700	20.94	-20.94	0.00	30.00	-30.00	peak		0	
6		298.37	8.93	-8.93	0.00	37.00	-37.00	peak		0	

\*:Maximum data    x:Over limit    !:over margin

●Reference Only

Receiver:  
Antenna: factor-060920  
Amplifier:

Spectrum Analyzer: FSP3  
Engineer Signature: Daniel

File : pu系列\Data :#3

Page : 1



環球認證有限公司  
Global Certification Cord.

Address:No.112-3,Shiang Chang Rd.,Sec.2,  
Hsi Chin,Taipei Hsien 221,Taiwan,R.O.C.  
Tel:02-26426992 Fax:02-26487450

**Radiated Emission Measurement**

File :pu系列 Data :#1 Date: 2006/11/23 Time: 下午 05:26:01

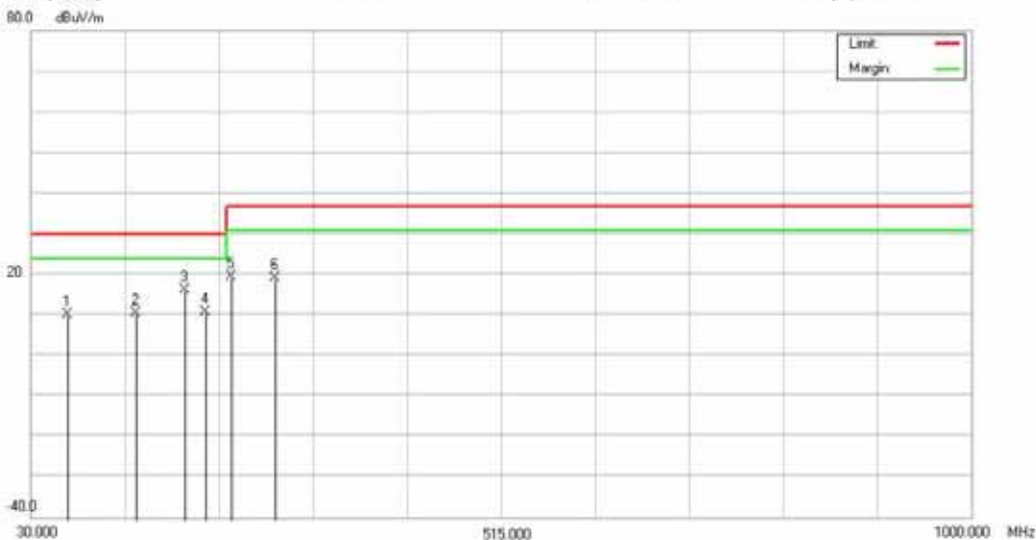

Site: Open site #1      Polarization: **Vertical**      Temperature: 24.6 °C  
 Limit: EN55022 Class B      Power: 5VDC      Humidity: 79 %  
 Company:      Distance: 10M RBW: 100 KHz  
 EUT: DC/DC Converter      Sweep Time: 100 ms  
 Model: PUS-0505A  
 Note: Full Load ; Vout ; 5V ; R ; 25Ω

No.	Mk.	Freq. MHz	Reading Level dBuV	Correct Factor dB	Measurement dBuV/m	Limit dBuV/m	Over dB	Antenna Height cm	Table Degree	Comment
1		68.8000	47.39	-37.28	10.11	30.00	-19.89	peak	0	
2		136.9800	32.80	-22.13	10.67	30.00	-19.33	peak	0	
3	*	187.4000	36.44	-20.25	16.19	30.00	-13.81	peak	0	
4		210.3900	31.30	-20.59	10.71	30.00	-19.29	peak	0	
5		237.1900	39.80	-20.30	19.50	37.00	-17.50	peak	0	
6		281.1100	41.21	-21.91	19.3	37.00	-17.7	peak	0	

\*:Maximum data    x:Over limit    !:over margin      •Reference Only

Receiver:      Spectrum Analyzer: FSP3  
 Antenna: factor:060920      Engineer Signature: Daniel  
 Amplifier:



環球認證有限公司  
Global Certification Cord.

Address:No.112-3,Shiang Chang Rd.,Sec.2,  
Hsi Chin,Taipei Hsien 221,Taiwan,R.O.C.  
Tel:02-26426992 Fax:02-26487450

**Radiated Emission Measurement**

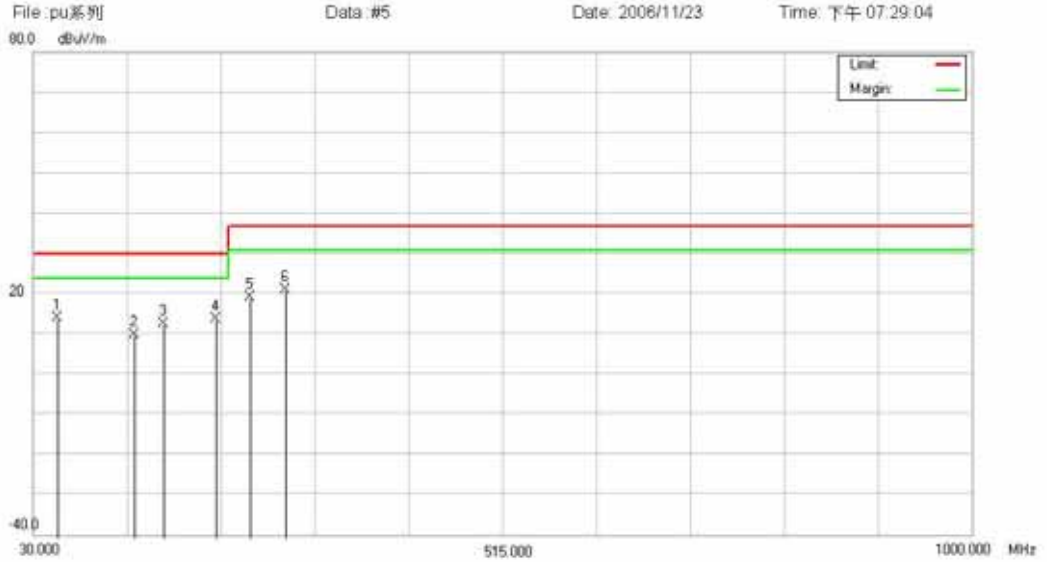

Site: Open site #1  
Limit: EN55022 Class B  
Company:  
EUT: DC/DC Converter  
Model: PUS-1205-3K  
Note: Full Load ; Vout ; 5V ; ; R; 25Ω

Polarization: **Vertical**  
Power: 12VDC  
Distance: 10M RBW: 100 KHz

Temperature: 24.6 °C  
Humidity: 79 %  
Sweep Time: 100 ms

No.	Mk.	Freq.	Reading Level	Correct Factor	Measurement	Limit	Over	Antenna Height	Table Degree
		MHz	dBuV	dB	dBuV/m	dBuV/m	dB	cm	degree
1	*	55.2100	51.36	-37.24	14.12	30.00	-15.88	peak	0
2		134.2900	32.69	-22.59	10.10	30.00	-19.90	peak	0
3		164.2900	31.37	-18.76	12.61	30.00	-17.39	peak	0
4		219.6800	34.79	-21.04	13.75	30.00	-16.25	peak	0
5		253.6700	41.29	-21.99	19.30	37.00	-17.70	peak	0
6		291.5900	41.10	-20.02	21.08	37.00	-15.92	peak	0

\*:Maximum data x:Over limit !:over margin

●Reference Only

Receiver:

Spectrum Analyzer: FSP3

Antenna: factor-060920

Engineer Signature: Daniel

Amplifier:

File :pu系列\Data :#5

Page: 1



環球認證有限公司  
Global Certification Corp.

Address:No.112-3,Shiang Chang Rd.,Sec.2,  
Hsi Chin,Taipei Hsien 221,Taiwan,R.O.C.  
Tel:02-26426992 Fax:02-26487450

**Radiated Emission Measurement**

File : pu系列      Data : #7      Date : 2006/11/23      Time : 下午 08:37:47

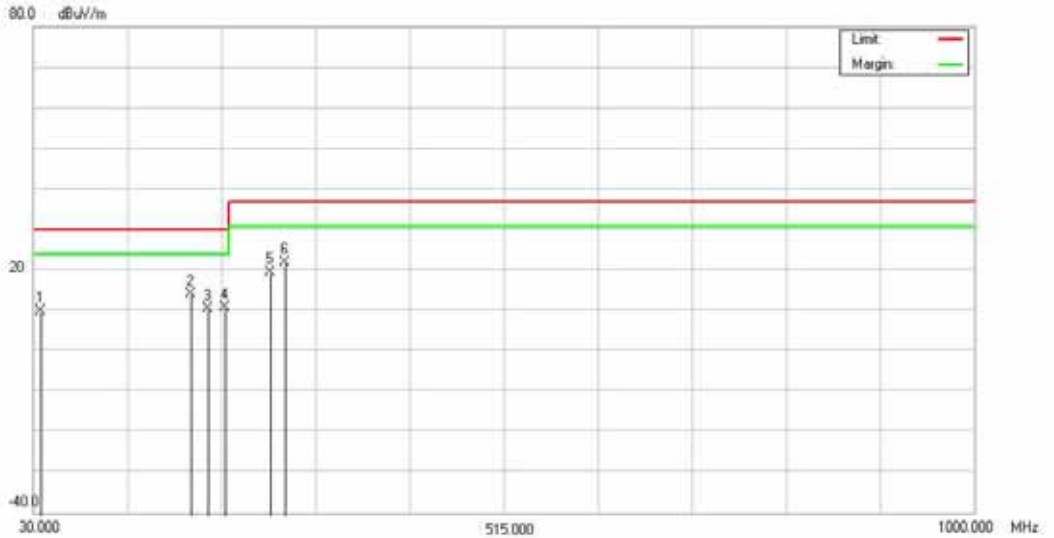

Site : Open site #1	Polarization: <b>Vertical</b>	Temperature: 24.6 °C
Limit: EN55022 Class B	Power: 12VDC	Humidity: 79 %
Company:	Distance: 10M RBW: 100 KHz	Sweep Time: 100 ms
EUT: DC/DC Converter		
Model : PUD-1212-2W		
Note: Full Load ; Vout1 ; +12V ; Vout2 ; -12V ; R1 & R2 ; 142.8Ω		

No.	Mk.	Freq.	Reading Level	Correct Factor	Measurement	Limit	Over	Antenna Height	Table Degree
		MHz	dBuV	dB	dBuV/m	dBuV/m	dB	cm	degree
1		36.8900	44.89	-34.96	9.93	30.00	-20.07	peak	0
2	*	191.4900	34.69	-20.45	14.24	30.00	-15.76	peak	0
3		210.1600	31.16	-20.56	10.60	30.00	-19.40	peak	0
4		227.1900	31.26	-20.30	10.96	30.00	-19.04	peak	0
5		274.3400	43.26	-23.77	19.49	37.00	-17.51	peak	0
6		289.1600	42.16	-20.32	21.84	37.00	-15.16	peak	0

\*:Maximum data    x:Over limit    !:over margin      ●Reference Only

Receiver:      Spectrum Analyzer: FSP3  
Antenna: factor-060920      Engineer Signature: Daniel  
Amplifier:

File : pu系列\Data : #7

Page: 1



環球認證有限公司  
Global Certification Corp.

Address:No.112-3,Shiang Chang Rd.,Sec.2,  
Hsi Chin,Taipei Hsien 221,Taiwan,R.O.C.  
Tel:02-26426992 Fax:02-26487450

**Radiated Emission Measurement**



Site: Open site #1	Polarization: <b>Vertical</b>	Temperature: 24.6 °C
Limit: EN55022 Class B	Power: 24VDC	Humidity: 79 %
Company:	Distance: 10M RBW: 100 KHz	
EUT: DC/DC Converter		Sweep Time: 100 ms
Model: PUS-2405-2W		
Note: Full Load ; Vout; 5VDC ; R1 ; 12.5Ω		

No.	Mk.	Freq.	Reading Level	Correct Factor	Measurement	Limit	Over	Antenna Height	Table Degree	
		MHz	dBuV	dB	dBuV/m	dBuV/m	dB	cm	degree	Comment
1		48.1600	44.19	-33.98	10.21	30.00	-19.79	peak	0	
2		67.1900	48.63	-38.00	10.63	30.00	-19.37	peak	0	
3		177.1900	31.16	-19.28	11.88	30.00	-18.12	peak	0	
4	*	198.4900	37.10	-21.77	15.33	30.00	-14.67	peak	0	
5		210.1900	34.10	-20.56	13.54	30.00	-16.46	peak	0	
6		287.2400	39.64	-20.75	18.89	37.00	-18.11	peak	0	

\*:Maximum data x:Over limit !:over margin ●Reference Only

Receiver: Spectrum Analyzer: FSP3  
 Antenna: factor-060920 Engineer Signature: Daniel  
 Amplifier:

File :pu系列\Data :#9

Page: 1





Address:No.112-3,Shiang Chang Rd.,Sec.2,  
Hsi Chin,Taipei Hsien 221,Taiwan,R.O.C.  
Tel:02-26426992 Fax:02-26487450

**Radiated Emission Measurement**



Site: Open site #1	Polarization: <b>Vertical</b>	Temperature: 34.6 °C
Limit: EN55022 Class B	Power: 12VDC	Humidity: 79 %
Company:	Distance: 10M RBW: 100 KHz	Sweep Time: 100 ms
EUT: DC/DC Converter		
Model: PUD-120512		
Note: Full Load ; Vout1 ;+ 5V ; Vout2 ;+12V ; R1; 50Ω ; R2; 285.7Ω		

No.	Mk.	Freq.	Reading Level	Correct Factor	Measurement	Limit	Over	Antenna Height	Table Degree
		MHz	dBuV	dB	dBuV/m	dBuV/m	dB	cm	degree
1		64.1900	48.36	-38.67	9.69	30.00	-20.31	peak	0
2		142.5800	34.69	-21.45	13.24	30.00	-16.76	peak	0
3	*	198.6100	36.68	-21.80	14.88	30.00	-15.12	peak	0
4		208.1900	31.78	-21.26	10.52	30.00	-19.48	peak	0
5		271.3600	39.68	-24.55	15.13	37.00	-21.87	peak	0
6		296.1800	41.50	-19.58	21.92	37.00	-15.08	peak	0

\*:Maximum data x:Over limit !:over margin ●Reference Only

Receiver: Spectrum Analyzer: FSP3  
 Antenna: factor:060920 Engineer Signature: Daniel  
 Amplifier:

File :pu系列\Data :#1 Page: 1



## **17. HARMONICS**

### **17.1 HARMONICS TEST**

Port:	AC mains
Active Input Power:	<75W
Basic Standard:	EN61000-3-2/AS/NZS 61000.3.2(details referred to Sec 2.2)
Test Procedure	refer to GCC
Test Duration:	2.5min
Class:	D

#### **Test Procedure**

The EUT is supplied in series with shunts or current transformers from a source having the same nominal voltage and frequency as the rated supply voltage and frequency of the EUT. The EUT is configured to its rated current with additional resistive load when the testing is performed.

Equipment having more than one rated voltage shall be tested at the rated voltage producing the highest harmonics as compared with the limits.

#### **Result**

The EUT's power is from DC source , so it is not necessary to be tested.



## **18. VOLTAGE FLUCTUATIONS**

### **18.1 VOLTAGE FLUCTUATIONS TEST**

Port:	AC mains
Basic Standard:	EN61000-3-3/AS/ AS/NZS 61000.3.3 (Details referred to Sec 2.2)
Test Procedure	Refer to GCC
Observation period:	For Pst 10min For Plt 2 hours

#### **Test Procedure**

The EUT is supplied in series with reference impedance from a power source with the voltage and frequency as the nominal supply voltage and frequency of the EUT.

#### **Result**

The EUT's power is from DC source , so it is not necessary to be tested.



## 19. ELECTROSTATIC DISCHARGE

Port:	Enclosure
Basic Standard:	EN61000-4-2/ IEC61000-4-2/ AS/NZS 61000.4.2 (details referred to Sec 2.2)
Test Level:	Air +/- 2 kV, +/- 4 kV, +/- 8 kV Contact +/- 2 kV, +/- 4 kV
Criteria:	A
Test Procedure	refer to GCC
Temperature:	27.9 degree C
Humidity:	54%

### **Test Setup**

EUT is 1m from the wall and other metallic structure. When Battery test mode is needed, a cable with one 470K( resister at two rare ends is connected from metallic part of EUT and screwed to HCP.

#### Selected Test Point

Air: discharges were applied to slots, aperture or insulating surfaces. 10 single air discharges were applied to each selected points.

Contact: Total 200 point minimum were to the selected contact points.

Indirect Contact Points: 25 discharges were applied to center of each edge of VCP and each EUT side of HCP with 10 cm away from EUT.

**TABEL 7 DIRECT APPLICATION OF DISCHARGE**

TESTPOINT	VOLTAGE	TEST NO.	OBSERVATION	RESULT
POWER CONNECTOR	$\pm 2 / \pm 4 / \pm 8$	By Air 10 / By Con.25	Normal	PASS



## **20. RADIO-FREQUENCY, ELECTROMAGNETIC FIELD IMMUNITY**

### **20.1 RADIO-FREQUENCY, ELECTROMAGNETIC FIELD IMMUNITY TEST**

Port:	Enclosure	
Basic Standard:	EN61000-4-3/ AS/NZS 61000.4.3 (details referred to Sec 2.2)	IEC61000-4-3
Test Level::	3V/m	N/A
Modulation:	AM 1KHz 80%	
Frequency range:	80 MHz~1 GHz	
Frequency Step:	1% of last step frequency	
Step time:	3s	
Polarization:	Vertical and Horizontal	
EUT Azimuth Angle	<input checked="" type="checkbox"/> 0° <input checked="" type="checkbox"/> 90° <input checked="" type="checkbox"/> 180° <input checked="" type="checkbox"/> 270°	
Criteria:	A	
Test Procedure	refer to GCC	
Temperature:	28.3 degree C	
Humidity:	56%	

#### **Test Setup**

The field sensor is placed at one calibration grid point to check the intensity of the established fields on both polarizations. EUT is adjusted to have each side of EUT face coincident with the calibration plane. A CCD camera and speakers are used to monitor the condition of EUT for the performance judgment.

#### **Test Result**

**Performance of EUT complies with the given specification.**



## 21. ELECTRICAL FAST TRANSIENTS/BURST IMMUNITY

### 21.1 ELECTRICAL FAST TRANSIENT/BURSTIMMUNITY TEST

Port:	DC mains
Basic Standard:	EN61000-4-4/AS/NZS 61000.4.4 (details referred to Sec 2.2)
Test Level:	DC Power Port: +/- 0.5 kV On/ I/O signal ,data and control line: +/- 0.5 kV
Rise Time:	5ns
Hold Time:	50ns
Repetition Frequency:	5KHz
Criteria:	A
Temperature:	27.9 degree C
Humidity:	54%

#### **Test Procedure**

The EUT was setup on a nonconductive table 0.8 m above a reference ground plane.

Test Points	Polarity	Result	Comment
Line	+	N	60 sec
	-	N	60 sec
Neutral	+	N	60 sec
	-	N	60 sec
Ground	+	N/A	60 sec
	-	N/A	60 sec
Line to Neutral	+	N	60 sec
	-	N	60 sec
Line to Ground	+	N/A	60 sec
	-	N/A	60 sec
Neutral to Ground	+	N/A	60 sec
	-	N/A	60 sec
Line to Neutral to Ground	+	N/A	60 sec
	-	N/A	60 sec

**Note: 'N' means normal, the EUT function is correct during the test.**



**Test Setup**

EUT is at least 50cm from the conductive structure .

The EUT adds a TVS component in this test.

**Test Result**

**Performance of EUT complies with the given specification.**



## **22. SURGE IMMUNITY**

### **22.1 SURGE IMMUNITY TEST**

Port:	DC mains;
Basic Standard:	EN61000-4-5/ IEC61000-4-5/ AS/NZS 61000.4.5 (details referred to Sec 2.2)
Test Level:	<b>DC Power Port</b> Line to Line: +/- 0.5
Rise Time:	1.2us
Hold Time:	50us
Repetition Rate:	30 second
Angle:	<input checked="" type="checkbox"/> 0° <input checked="" type="checkbox"/> 90° <input checked="" type="checkbox"/> 270°
Criteria:	A
Test Procedure	refer to GCC
Temperature:	27.9 degree C
Humidity:	54%

#### **Test Setup**

DC power supply and Voltage Supply to EUT.

The EUT adds a TVS component in this test.

#### **Test Result**

**Performance of EUT complies with the given specification.**



## 23. IMMUNITY TO CONDUCTIVE DISTURBANCE

Port:	DC mains;	
Basic Standard:	EN61000-4-6/AS/NZS 61000.4.6 (details referred to Sec 2.2)	IEC61000-4-6
Test Level::	3 V	N/A
Modulation:	AM 1KHz 80%	
Frequency range:	0.15 MHz - 80MHz	
Frequency Step:	1% of last Frequency	
Step time:	3s	
Criteria:	A	
Test Procedure	refer to GCC	
Temperature:	27.9 degree C	
Humidity:	54%	

### **Test Result**

**Performance of EUT complies with the given specification.**

**24. POWER FREQUENCY MAGNETIC FIELD IMMUNITY**

Port:	Enclosure	
Basic Standard:	EN61000-4-8/AS/NZS 61000.4.8 (details referred to Sec 2.2)	IEC61000-4-8
Test Level:	1A/m	N/A
Polarization:	X, Y, Z	
Criteria:	A	
Test Procedure	refer to GCC	
Temperature:	27.9 degree C	
Humidity:	54%	

**Test Setup**

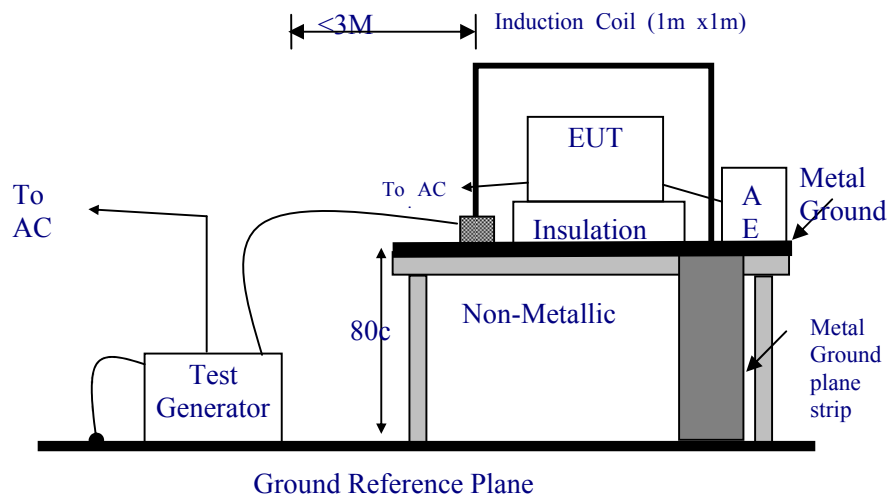

**Test Result**

**Performance of EUT complies with the given specification.**

**25. VOLTAGE DIPS, SHORT INTERRUPTION AND VOLTAGE VARIATION IMMUNITY**

Port:	AC mains	
Basic Standard:	EN61000-4-11/ AS/NZS 61000.4.11 (details referred to Sec 2.2)	IEC61000-4-11
Test Level: Criteria:	>95% in 10ms A	>95% in 10ms A
Test Level: Criteria:	30% in 500ms A	30% in 500ms A
Test Level: Criteria:		30% in 500ms A
Test Level: Criteria:	>95% in 5000ms B	>95% in 5000ms B
Phase:	0°,45°,90°; 135°,180°; 225°,270°; 315°,360°	
Test intervals:	3 times with 10s each	
Test Procedure	refer to GCC	
Temperature:	27.9 degree C	
Humidity:	54%	

**Test Setup**

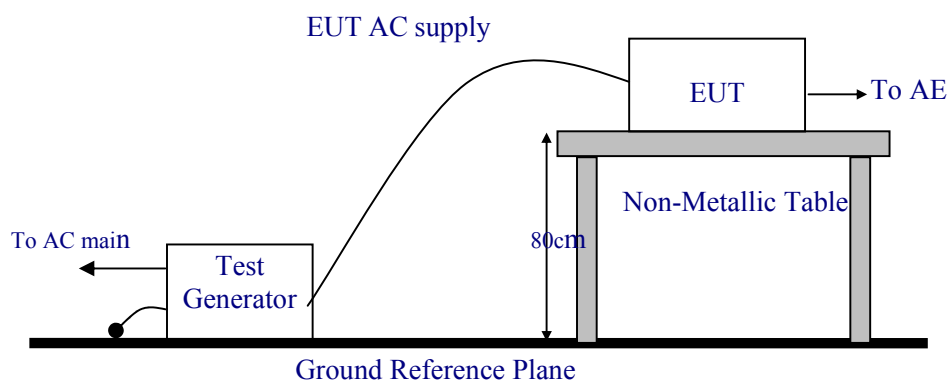

**Test Result**

The EUT's power is from DC source , so it is not necessary to be tested.

## 26. Appendix I – Photographs of test setup

### Radiated emission test





**Electrostatic Discharge**



**Radio-frequency electromagnetic field**

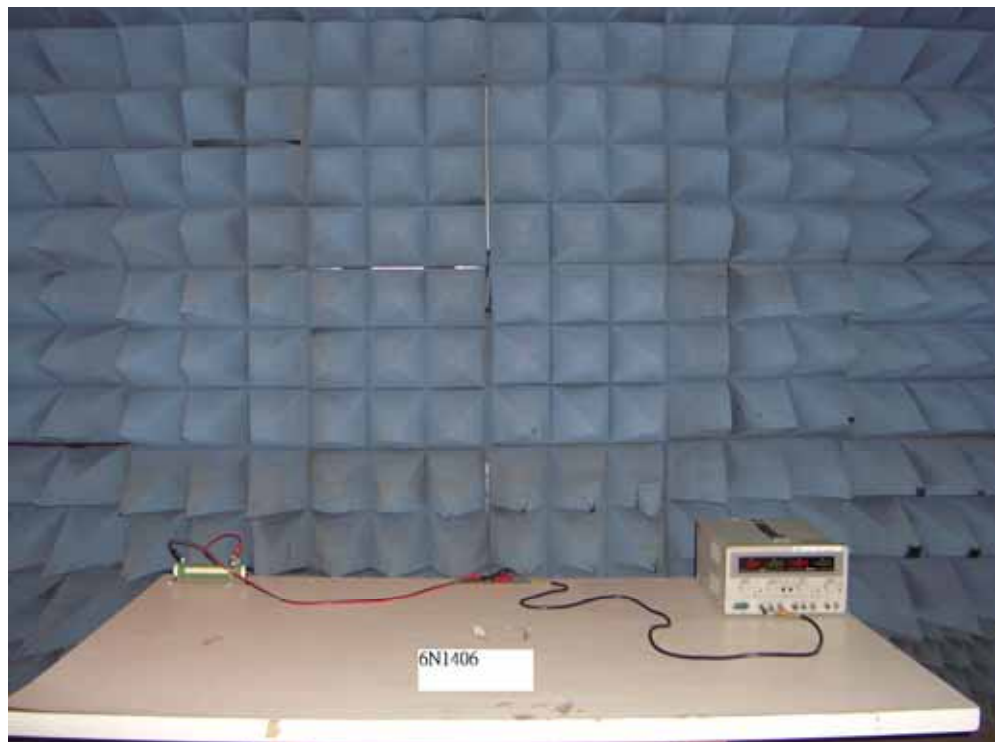



**Electrical Fast transients common mode**



**Surge immunity test common mode**



**Power Frequency Magnetic Field immunity**



**Conducted disturbances Induced by Radio-frequency Field immunity**

